

7SR11 and 7SR12

Description of Operation

Document Release History

This document is issue 2012/02. The list of revisions up to and including this issue is:

2012/02	AC auxiliary power supply added
2012/01	Software Maintenance
2011/06	Software Maintenance
2010/04	Amendments following PLM review
2010/02	Document reformat due to rebrand
2009/09	Format and relay fascia revised.
2009/04	First Issue

Software Revision History

2012/01	7SR11 2436H80003 R2a-2a 7SR12 2436H80004 R2a-2a	Software Maintenance
2011/06	7SR11 2436H80003 R2-2 7SR12 2436H80004 R2-2	Software Maintenance
2009/04	2436H80003R1g-1c 7SR11 2436H80004R1g-1c 7SR12	First Release

The copyright and other intellectual property rights in this document, and in any model or article produced from it (and including any registered or unregistered design rights) are the property of Siemens Protection Devices Limited. No part of this document shall be reproduced or modified or stored in another form, in any data retrieval system, without the permission of Siemens Protection Devices Limited, nor shall any model or article be reproduced from this document unless Siemens Protection Devices Limited consent.

While the information and guidance given in this document is believed to be correct, no liability shall be accepted for any loss or damage caused by any error or omission, whether such error or omission is the result of negligence or any other cause. Any and all such liability is disclaimed.

Contents

Section 1: Introduction	7
1.1 Current Transformer Circuits.....	7
1.2 External Resistors	7
1.3 Front Cover	7
Section 2: Hardware Description.....	15
2.1 General	15
2.2 Case.....	15
2.3 Front Cover	16
2.4 Power Supply Unit (PSU).....	17
2.5 Operator Interface/ Fascia	18
2.6 Current Inputs	21
2.7 Voltage Inputs	21
2.8 Binary Inputs	21
2.9 Binary Outputs (Output Relays)	22
2.10 Virtual Input/Outputs	23
2.11 Self Monitoring	24
2.11.1 Protection Healthy/Defective.....	24
Section 3: Protection Functions	26
3.1 Current Protection: Phase Overcurrent (67, 51, 50).....	26
3.1.1 Directional Control of Overcurrent Protection (67) – 7SR12	26
3.1.2 Instantaneous Overcurrent Protection (50)	27
3.1.3 Time Delayed Overcurrent Protection (51).....	28
3.1.4 Current Protection: Voltage Controlled Overcurrent (51V) - 7SR12.....	30
3.2 Current Protection: Derived Earth Fault (67N, 51N, 50N)	31
3.2.1 Directional Control of Derived Earth Fault Protection (67N) – 7SR12.....	31
3.2.2 Instantaneous Derived Earth Fault Protection (50N).....	32
3.2.3 Time Delayed Derived Earth Fault Protection (51N)	32
3.3 Current Protection: Measured Earth Fault (67G, 51G, 50G).....	34
3.3.1 Directional Control of Measured Earth Fault Protection (67G) – 7SR12	34
3.3.2 Instantaneous Measured Earth Fault Protection (50G).....	35
3.3.3 Time Delayed Measured Earth Fault Protection (51G)	36
3.4 Current Protection: Sensitive Earth Fault (67SEF, 51SEF, 50SEF).....	37
3.4.1 Directional Control of Sensitive Earth Fault Protection (67SEF) – 7SR12	37
3.4.2 Instantaneous Sensitive Earth Fault Protection (50SEF)	38
3.4.3 Time Delayed Sensitive Earth Fault Protection (51SEF)	40
3.5 Current Protection: High Impedance Restricted Earth Fault - (64H)	42
3.6 Current Protection: Cold Load (51c)	42
3.7 Current Protection: Negative Phase Sequence Overcurrent - (46NPS).....	43
3.8 Current Protection: Under-Current (37).....	44
3.9 Current Protection: Thermal Overload (49).....	45
3.10 Current Protection: Line Check 50LC, 50G LC and 50SEF LC – Only software option ‘C’	46
3.11 Voltage Protection: Phase Under/Over Voltage (27/59) – 7SR12	47
3.12 Voltage Protection: Negative Phase Sequence Overvoltage (47) – 7SR12.....	49
3.13 Voltage Protection: Neutral Overvoltage (59N) – 7SR12	49
3.14 Voltage Protection: Under/Over Frequency (81) – 7SR12	50
Section 4: Control & Logic Functions	52
4.1 Auto-Reclose (79) Optional Function	52
4.1.1 Overview	52
4.1.2 Auto Reclose sequences	53
4.1.3 Autoreclose Prot'n Menu.....	54
4.1.4 Autoreclose Config Menu.....	54
4.1.5 P/F Shots sub-menu	56
4.1.6 E/F Shots sub-menu	56
4.1.7 SEF Shots sub-menu	56

4.1.8	Extern Shots sub-menu.....	56
4.2	Manual CB Control.....	59
4.3	Circuit Breaker (CB).....	59
4.4	Quick Logic	62
Section 5:	Supervision Functions.....	64
5.1	Circuit Breaker Failure (50BF)	64
5.2	VT Supervision (60VTS) – 7SR1205 & 7SR1206	65
5.3	CT Supervision (60CTS).....	67
5.3.1	60CTS for 7SR11 (60CTS-I for 7SR12).....	67
5.3.2	60CTS for 7SR12.....	67
5.4	Broken Conductor (46BC).....	68
5.5	Trip/ Close Circuit Supervision (74TCS & 74CCS)	68
5.6	2nd Harmonic Block/Inrush Restraint (81HBL2) phase elements only.....	70
Section 6:	Other Features.....	71
6.1	Data Communications.....	71
6.2	Maintenance	71
6.2.1	Output Matrix Test	71
6.2.2	CB Counters	71
6.2.3	I ² t CB Wear.....	71
6.3	Data Storage.....	71
6.3.1	General	71
6.3.2	Demand	72
6.3.3	Event Records	72
6.3.4	Waveform Records.....	72
6.3.5	Fault Records.....	73
6.3.6	Energy Storage - 7SR12.....	73
6.4	Metering.....	74
6.5	Operating Mode	75
6.6	Control Mode	75
6.7	Real Time Clock.....	75
6.7.1	Time Synchronisation – Data Communication Interface	76
6.7.2	Time Synchronisation – Binary Input	76
6.8	Settings Groups	76
6.9	Password Feature.....	76

List of Figures

Figure 1-1 Functional Diagram of 7SR1101-1_A12-_CA0 Relay	9
Figure 1-2 Functional Diagram of 7SR1101-3_A12-_CA0 Relay	9
Figure 1-3 Functional Diagram of 7SR1103-1_A12-_DA0 Relay	9
Figure 1-4 Functional Diagram of 7SR1103-3_A12-_DA0 Relay	9
Figure 1-5 Connections Diagram for 7SR11 Relay	10
Figure 1-6 Functional Diagram of 7SR1204-2_A12-_CA0 Relay	12
Figure 1-7 Functional Diagram of 7SR1204-4_A12-_CA0 Relay	12
Figure 1-8 Functional Diagram of 7SR1205-2_A12-_DA0 Relay	13
Figure 1-9 Functional Diagram of 7SR1205-4_A12-_DA0 Relay	13
Figure 1-10 Connections Diagram for 7SR12 Relay	14
Figure 1-11 Relay shown withdrawn	16
Figure 1-12 7SR11 Rear view of 7SR11 Relay	16
Figure 1-13 Earth connection Symbol	16
Figure 1-14 Relay with standard transparent cover	17
Figure 1-15 Relay with transparent cover and push buttons	17
Figure 1-16 Relay with Transparent cover removed	18
Figure 1-17 Close up of Relay Label	18
Figure 1-18 Close up of Relay Identifier	19
Figure 1-19 LED Indication Label	21
Figure 1-20 Binary Input Logic	22
Figure 1-21 Binary Output Logic	23
Figure 1-22 Start-up Counter Meter	24
Figure 1-23 Start-up Events	25
Figure 1-24 Logic Diagram: Directional Overcurrent Element (67)	27
Figure 1-25 Logic Diagram: Instantaneous Over-current Element	28
Figure 1-26 Logic Diagram: Time Delayed Overcurrent Element	29
Figure 1-27 Logic Diagram: Voltage Controlled Overcurrent Protection	30
Figure 1-28 Logic Diagram: Derived Directional Earth Fault Element	31
Figure 1-29 Logic Diagram: Derived Instantaneous Earth Fault Element	32
Figure 1-30 Logic Diagram: Derived Time Delayed Earth Fault Protection	33
Figure 1-31 Logic Diagram: Measured Directional Earth Fault Protection	34
Figure 1-32 Logic Diagram: Measured Instantaneous Earth-fault Element	35
Figure 1-33 Logic Diagram: Measured Time Delayed Earth Fault Element (51G)	36
Figure 1-34 Logic Diagram: SEF Directional Element (67SEF)	38
Figure 1-35 Logic Diagram: 7SR11 SEF Instantaneous Element	38
Figure 1-36 Logic Diagram: 7SR12 SEF Instantaneous Element	39
Figure 1-37 Logic Diagram: 7SR11 SEF Time Delayed Element (51SEF)	40
Figure 1-38 Logic Diagram: 7SR12 SEF Time Delayed Element (51SEF)	41
Figure 1-39 Logic Diagram: High Impedance REF (64H)	42
Figure 1-40 Logic Diagram: Cold Load Settings (51c)	43
Figure 1-41 Logic Diagram: Negative Phase Sequence Overcurrent (46NPS)	44
Figure 1-42 Logic Diagram: Phase Current Inputs Undercurrent Detector (37)	44
Figure 1-43 Logic Diagram: Earth Current Inputs Undercurrent Detector (37G)	45
Figure 1-44 Logic Diagram: Sensitive Earth Current Inputs Undercurrent Detector (37SEF)	45
Figure 1-45 Logic Diagram: Thermal Overload Protection (49)	46
Figure 1-46 Logic Diagram: 50G Line Check Elements (50G LC)	46
Figure 1-47 Logic Diagram: 50SEF Line Check Elements (50SEF LC)	47
Figure 1-48 Logic Diagram: 50 Line Check Elements (50LC)	47
Figure 1-49 Logic Diagram: Under/Over Voltage Elements (27/59)	48
Figure 1-50 Logic Diagram: NPS Overvoltage Protection (47)	49

Figure 1-51 Logic Diagram: Neutral Overvoltage Element (59N).....	50
Figure 1-52 Logic Diagram: Under/Over Frequency Detector (81)	51
Figure 4-1 Typical AR Sequence with 3 Inst and 1 Delayed trip	54
Figure 4-2 Basic Auto-Reclose Sequence Diagram.....	58
Figure 4-3 Logic Diagram: Circuit Breaker Status.....	60
Figure 4-4 Sequence Diagram: Quick Logic PU/DO Timers (Counter Reset Mode Off).....	63
Figure 4-5 Logic Diagram: Circuit Breaker Fail Protection (50BF).....	64
Figure 4-6 Logic Diagram: VT Supervision Function (60VTS)	66
Figure 4-7 Logic Diagram: CT Supervision Function (60CTS) – 7SR11	67
Figure 4-9 Logic Diagram: CT Supervision Function (60CTS) – 7SR12	68
Figure 4-10 Logic Diagram: Broken Conductor Function (46BC).....	68
Figure 4-11 Logic Diagram: Trip Circuit Supervision Feature (74TCS).....	69
Figure 4-12 Logic Diagram: Close Circuit Supervision Feature (74CCS)	69
Figure 4-13 Functional Diagram for Harmonic Block Feature (81HBL2).....	70
Figure 4-14 Energy Direction Convention	73

List of Tables

Table 1-1	7SR11 Ordering Options	8
Table 1-2	7SR12 Ordering Options	11
Table 1-3	Summary of 7SR1 Relay Configurations	15
Table 4-1	Operating Mode.....	75

Symbols and Nomenclature

The following notational and formatting conventions are used within the remainder of this document:

- Setting Menu Location MAIN MENU>SUB-MENU
- Setting: ***Elem name -Setting***
- Setting value: **value**
- Alternatives: **[1st] [2nd] [3rd]**

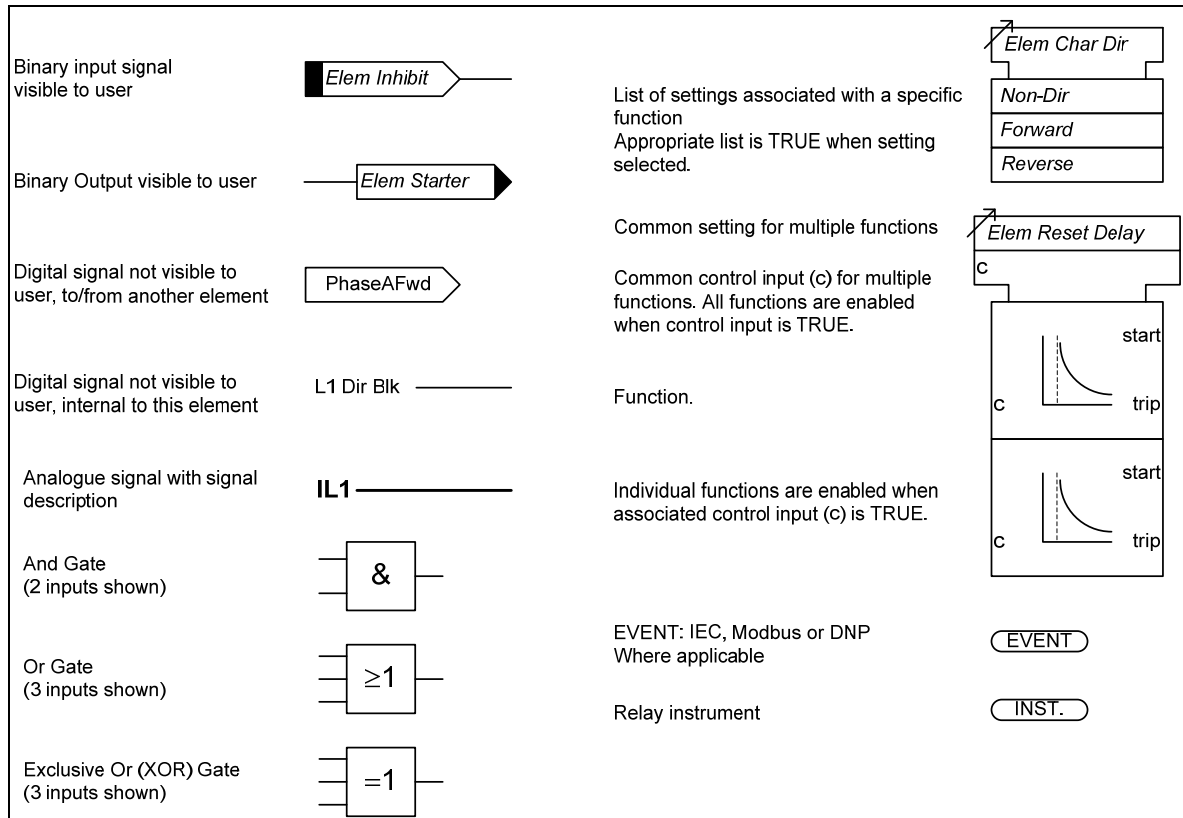

Section 1: Introduction

This manual is applicable to the following relays:

- 7SR11 Overcurrent and Earth Fault Relay
- 7SR12 Directional Overcurrent and Directional Earth Fault Relay

The 'Ordering Option' Tables summarise the features available in each model

General Safety Precautions



1.1 Current Transformer Circuits

The secondary circuit of a live CT must not be open circuited. Non-observance of this precaution can result in injury to personnel or damage to equipment.



1.2 External Resistors

Where external resistors are connected to the relay circuitry, these may present a danger of electric shock or burns, if touched.



1.3 Front Cover

The front cover provides additional securing of the relay element within the case. The relay cover should be in place during normal operating conditions.

Table 1-1 7SR11 Ordering Options

		7	S	R	1	0	□	-	□	□	A	1	2	-	□	□	A	0
		↑	↑	↑	↑	↑	↑	↑	↑	↑	↑	↑	↑	↑	↑	↑	↑	↑
Nondirectional O/C Relay																		
Overcurrent and earth fault protection relay																		
<u>Protection Product</u>																		
Overcurrent – Non Directional						1												
<u>Case I/O and Fascia</u>																		
E4 case, 1 CT, 3 Binary Inputs / 5 Binary Outputs, 10 LEDs						1											C	
E4 case, 4 CT, 3 Binary Inputs / 5 Binary Outputs, 10 LEDs						2											C/D	
E4 case, 4 CT, 6 Binary Inputs / 8 Binary Outputs, 10 LEDs						3											C/D	
<u>Measuring Input</u>																		
1/5 A, 50/60Hz ¹⁾										1								
1/5 A, 50/60Hz with SEF Input ²⁾										3								
<u>Auxiliary voltage</u>																		
80 to 250V DC, 115V RMS AC, binary input threshold 19V DC ⁶⁾											G							
80 to 250V DC, binary input threshold 88V DC											H							
24 to 60V DC, binary input threshold 19V DC											J							
<u>Communication Interface</u>																		
Standard version – included in all models, USB front port, RS485 rear port													1					
<u>Protocol</u>																		
IEC 60870-5-103 and Modbus RTU and DNP3 (user selectable setting)													2					
<u>Relay Cover</u>																		
Standard Version – No Push Buttons																		1
Push Buttons – Down and Right Arrows																		2
<u>Protection Function Packages</u>																		
Basic version ⁵⁾ – included in all models																		A
46BC ³⁾ Broken conductor/load unbalance																		
50 ³⁾ Instantaneous phase fault overcurrent																		
50BF ³⁾ Circuit breaker fail																		
50G/50N Instantaneous earth fault																		
51 ³⁾ Time delayed phase fault overcurrent																		
51G/51N Time delayed earth fault/SEF																		
60CTS-1 ³⁾ CT Supervision																		
64H High Impedance REF																		
74T/CC Trip/Close circuit supervision																		
86 Hand reset contacts																		
Standard version – as basic plus																		C
37 Undercurrent																		
46NPS ³⁾ Negative phase sequence overcurrent																		
49 ³⁾ Thermal overload																		
50SEF ²⁾ Instantaneous sensitive earth fault																		
51SEF ²⁾ Time delayed sensitive earth fault																		
81HBL ²⁾ 2 nd Harmonic Block/Inrush Restraint																		
51c ³⁾ Cold load pickup																		
Programmable logic																		
Standard version – plus																		D
79 Autoreclose																		
<u>Additional Functionality</u>																		
No Additional Functionality																		A

1) 4CT is configured as 3PF + EF.
 2) 4CT is configured as 3PF + SEF.
 3) Functions only available in 4CT relay
 4) Not available on single-pole SEF variant
 5) Protection function package ordering option A is only available on hardware variant 7SR1102-1xA12-xAA0 – 4CT 3BI 5BO
 6) AC Auxiliary voltage option not available on hardware versions earlier than /CC

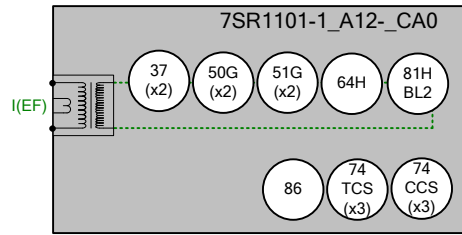

Figure 1-1 Functional Diagram of 7SR1101-1_A12-CA0 Relay

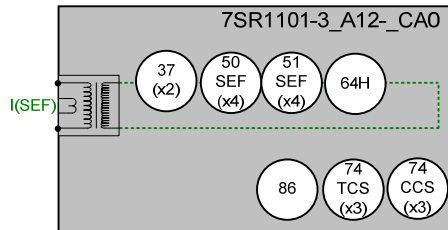

Figure 1-2 Functional Diagram of 7SR1101-3_A12-CA0 Relay

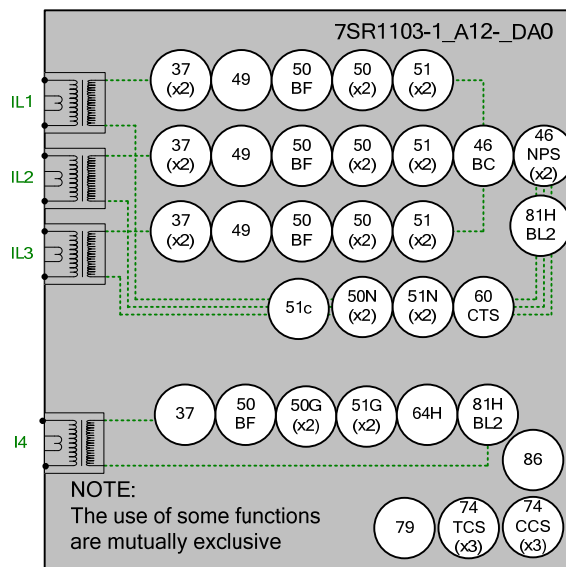

Figure 1-3 Functional Diagram of 7SR1103-1_A12-DA0 Relay

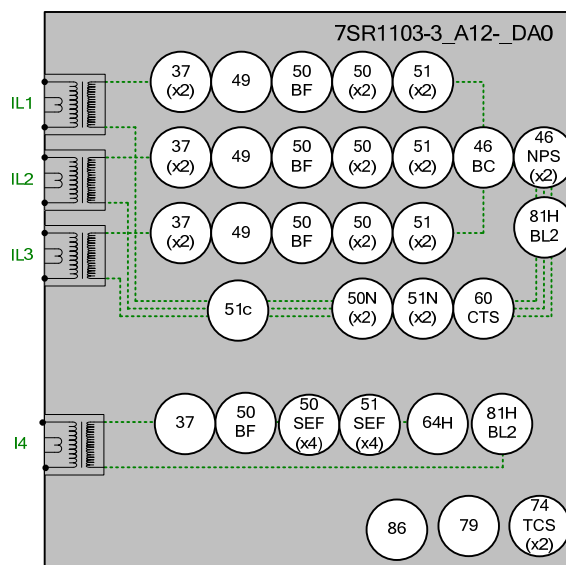

Figure 1-4 Functional Diagram of 7SR1103-3_A12-DA0 Relay

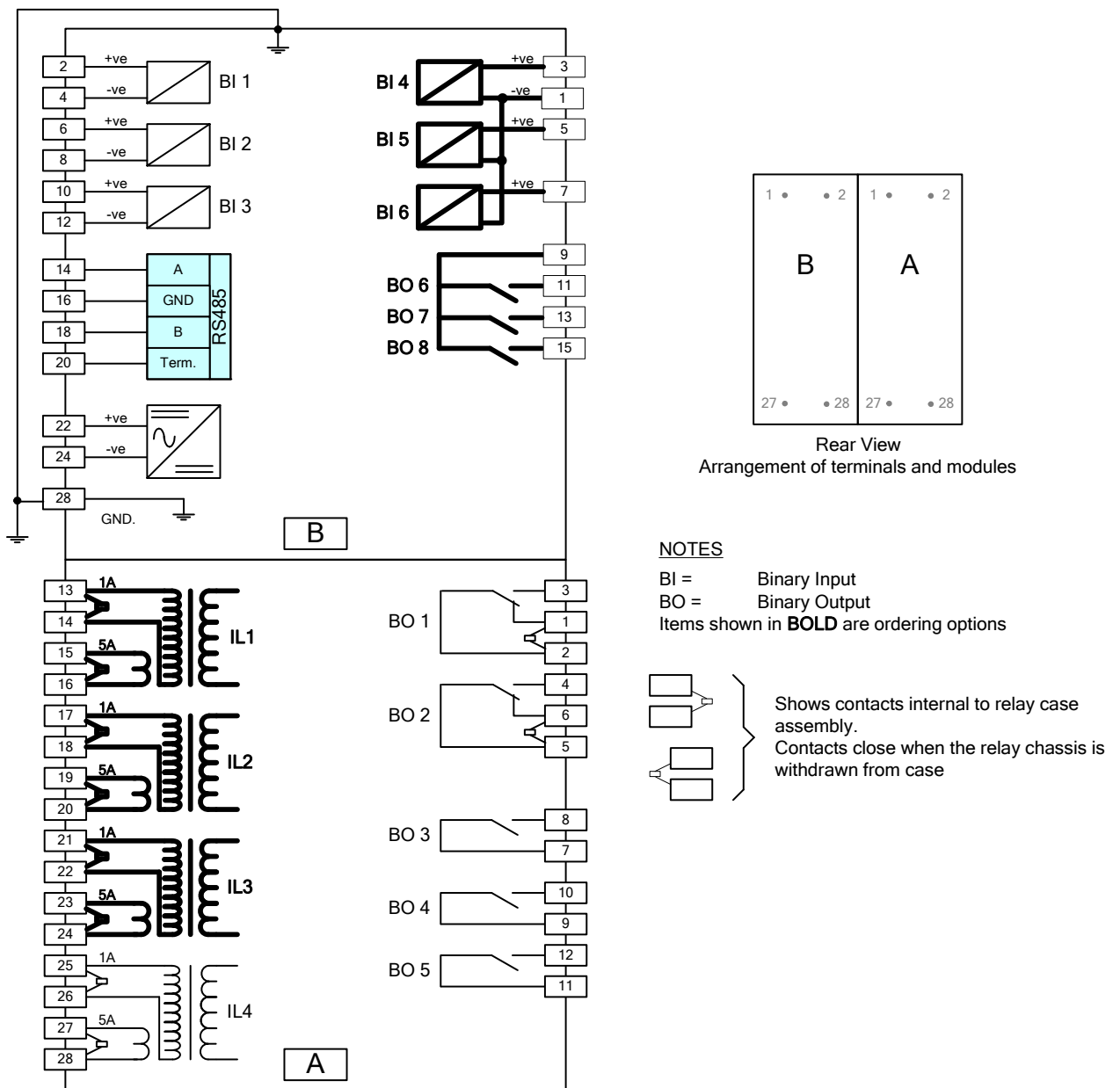

Figure 1-5 Connections Diagram for 7SR11 Relay

Table 1-2 7SR12 Ordering Options

Directional O/C Relay	7	S	R	1	2	0	□	-	□	□	A	□	2	-	□	□	A	0
Directional Overcurrent and earth Fault Protection relay					↑	↑	↑	↑	↑	↑	↑	↑	↑	↑	↑	↑	↑	↑
<u>Protection Product</u>						2												
Overcurrent – Directional																		
<u>Case I/O and Fascia</u>																		
E4 case, 1 CT, 3VT, 3 Binary Inputs / 5 Binary Outputs, 10 LEDs							4										C	
E4 case, 4 CT, 3VT, 3 Binary Inputs / 5 Binary Outputs, 10 LEDs							5											
E4 case, 4 CT, 3VT, 6 Binary Inputs / 8 Binary Outputs, 10 LEDs							6											
<u>Measuring Input</u>																		
1/5 A, 63.5/110V, 50/60Hz								2										
1/5 A, 63.5/110V, 50/60Hz with SEF								4										
<u>Auxiliary voltage</u>																		
80 to 250V DC, 115V RMS AC, binary input threshold 19V DC ⁵⁾										G								
80 to 250V DC, binary input threshold 88V DC										H								
24 to 60V DC, binary input threshold 19V DC										J								
<u>Communication Interface</u>																		
Standard version – included in all models, USB front port, RS485 rear port												1						
<u>Protocol</u>																		
IEC 60870-5-103 and Modbus RTU and DNP3 (user selectable setting)													2					
<u>Relay Cover</u>																		
Standard Version – No Push Buttons																		1
Push Buttons – Down and Right Arrows																		2
<u>Protection Function Packages</u>																		
Standard version – Included in all models																		C
27/59 Under/overvoltage																		
37 Undercurrent																		
46BC ³⁾ Broken conductor/load unbalance																		
46NPS ³⁾ Negative phase sequence overcurrent																		
47 ³⁾ Negative phase sequence voltage																		
49 ³⁾ Thermal overload																		
50BF ³⁾ Circuit breaker fail																		
51V ³⁾ Voltage dependent overcurrent																		
59N Neutral voltage displacement																		
60CTS ³⁾ CT supervision																		
60VTS ³⁾ VT supervision																		
64H High Impedance REF																		
67/50 ³⁾ Directional instantaneous phase fault overcurrent																		
67/50G 67/50N Directional instantaneous earth fault																		
67/50SEF ²⁾ Directional instantaneous sensitive earth fault																		
67/51 ³⁾ Directional time delayed phase fault overcurrent																		
67/51G 67/51N Directional time delayed earth fault																		
67/51SEF ²⁾ Directional time delayed sensitive earth fault																		
81HBL2 ⁴⁾ 2 nd Harmonic Block/Inrush Restraint																		
81U/O Under/Over Frequency																		
74T/CC Trip/Close circuit supervision																		
51c ³⁾ Cold load pickup																		
86 Hand reset contacts Programmable logic																		
Standard version – plus																		D
79 Autoreclose																		
<u>Additional Functionality</u>																		
No Additional Functionality																		A

1) 4CT is configured as 3PF + EF.

2) 4CT is configured as 3PF + SEF.

3) Functions only available in 4CT relay

4) Not available on single-pole SEF variant

5) AC Auxiliary voltage option not available on hardware versions earlier than /CC

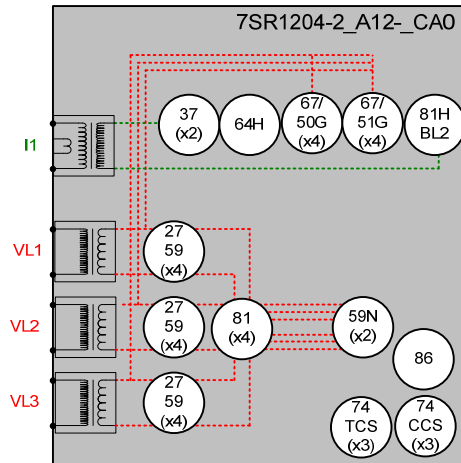

Figure 1-6 Functional Diagram of 7SR1204-2_A12-CA0 Relay

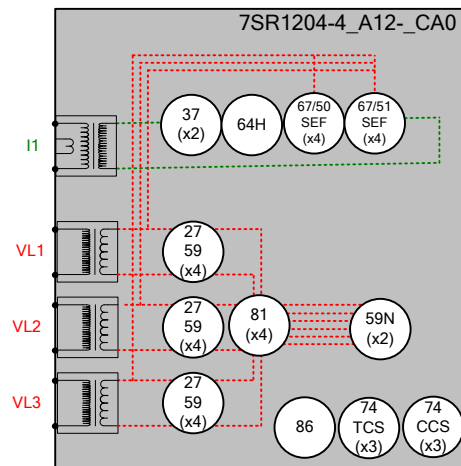

Figure 1-7 Functional Diagram of 7SR1204-4_A12-CA0 Relay

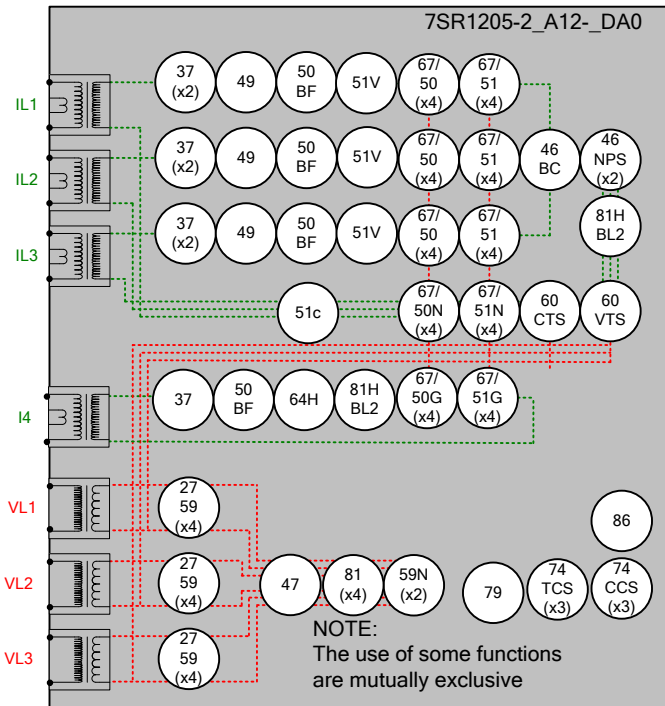

Figure 1-8 Functional Diagram of 7SR1205-2_A12-DA0 Relay

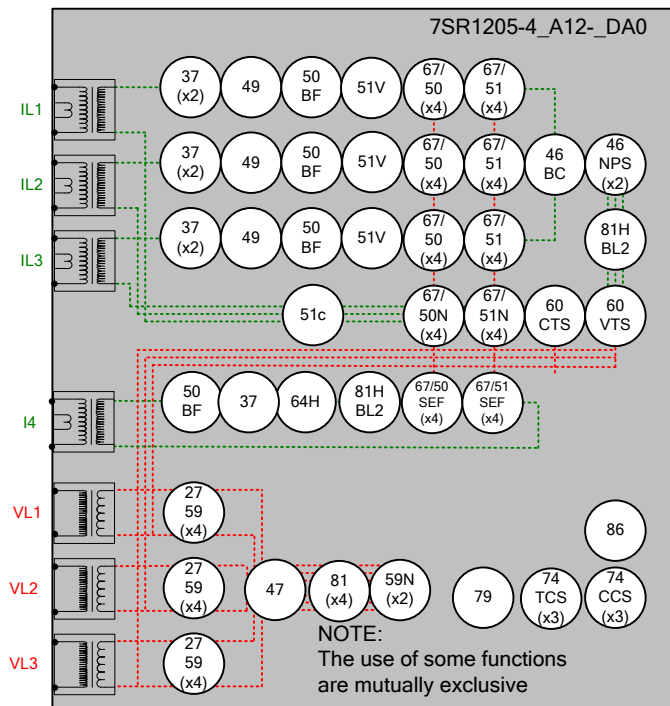

Figure 1-9 Functional Diagram of 7SR1205-4_A12-DA0 Relay

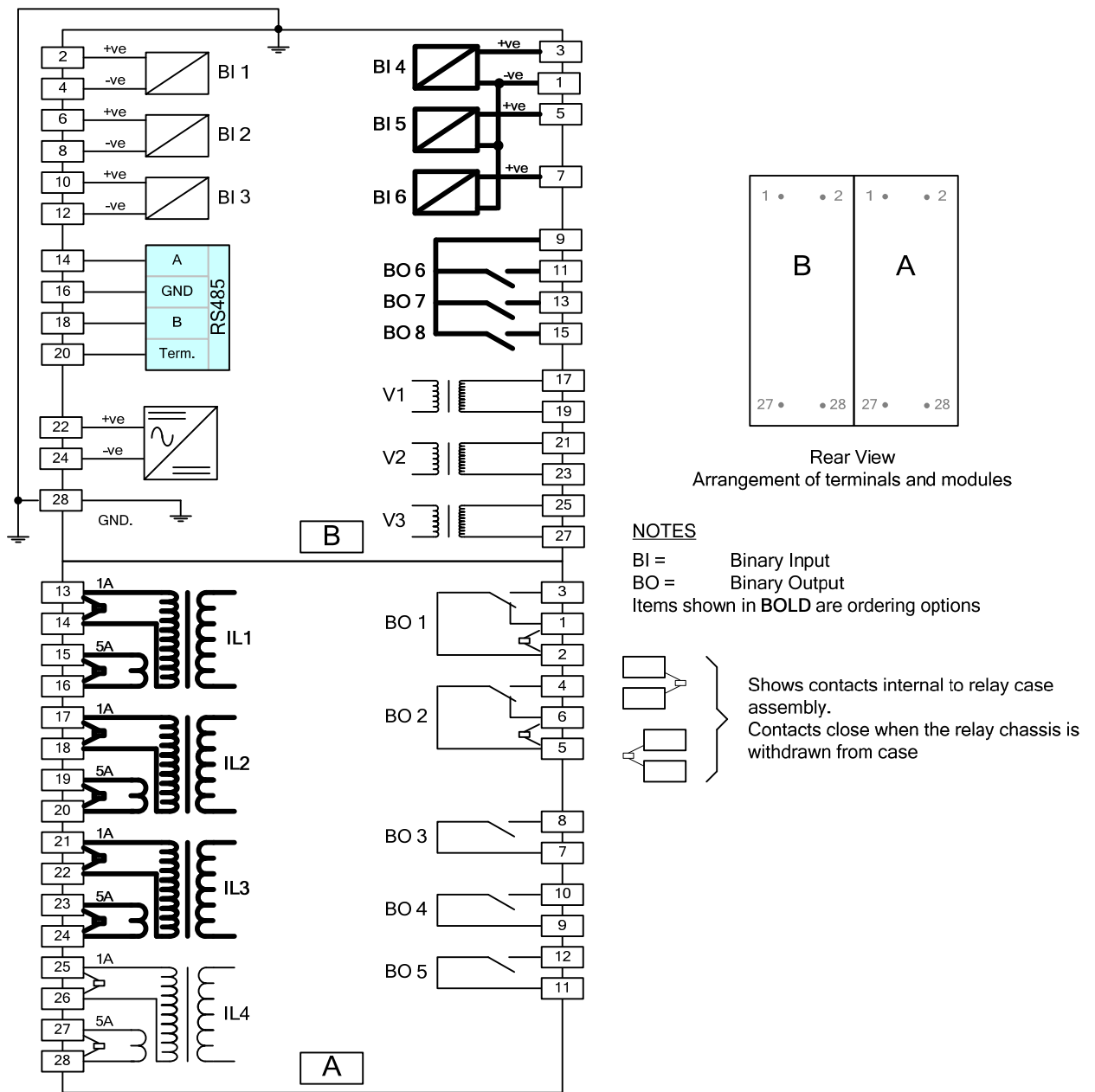

Figure 1-10 Connections Diagram for 7SR12 Relay

Section 2: Hardware Description

2.1 General

The structure of the relay is based upon the Reyrolle Compact hardware platform. The relays are supplied in a size E4 case (where 1 x E = width of approx. 26mm). The hardware design provides commonality between products and components across the Reyrolle Compact range of relays.

Table 1-3 Summary of 7SR1 Relay Configurations

Relay	Current Inputs	SEF Inputs	Voltage Inputs	Binary Inputs	Binary Outputs	LEDs
7SR1101-1	1	0	0	3	5	10
7SR1101-3	1	1	0	3	5	10
7SR1102-1	4	0	0	3	5	10
7SR1102-3	4	1	0	3	5	10
7SR1103-1	4	0	0	6	8	10
7SR1103-3	4	1	0	6	8	10
7SR1204-2	1	0	3	3	5	10
7SR1204-4	1	1	3	3	5	10
7SR1205-2	4	0	3	3	5	10
7SR1205-4	4	1	3	3	5	10
7SR1206-2	4	0	3	6	8	10
7SR1206-4	4	1	3	6	8	10

Relays are assembled from the following modules:

- 1) Front Fascia with 9 configurable LEDs and 1 Relay Healthy LED.
- 2) Processor module.
- 3) Current Analogue / Output module
 - 1 x Current + 5 x Binary Outputs (BO)
 - 4 x Current + 5 x Binary Outputs (BO)
- 4) Voltage Analogue / Input / output module
 - 3 x Voltage + 3 x Binary Input and 3 x Binary Output Module. (7SR12)
 - 3 x Binary Input (BI) and 3 x Binary Output (BO) Module.
- 5) Power Supply and 3 x Binary Input (BI) and RS485.

2.2 Case

The relays are housed in cases designed to fit directly into standard panel racks. The case has a width of 104mm and a height of 177 mm (4U). The required panel depth (with wiring clearance) is 242 mm.

The complete relay assembly is withdrawable from the front of the case. Contacts in the case ensure that the CT circuits and normally closed contacts remain short-circuited when the relay is removed. To withdraw the relay, remove the plastic fascia cover by rotating the two securing pins and withdraw using the plastic handles. The relay should not be carried using these handles. The relay should only be held by the top and bottom plates and the user should not touch the exposed PCB's.



Figure 1-11 Relay shown withdrawn

The rear terminal blocks comprise M4 female terminals for wire connections. Each terminal can accept two 4mm crimps.



Figure 1-12 7SR11 Rear view of 7SR11 Relay

Located at the top rear of the case is a screw clamp earthing point, this must be connected to terminal 28 and directly to the main panel earth. This connection point is indicated by the following symbol.

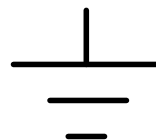

Figure 1-13 Earth connection Symbol

2.3 Front Cover

As standard the relay is supplied with a transparent front cover. The front cover is used to secure the relay assembly in the case.



Figure 1-14 Relay with standard transparent cover

If access is required to view the menus without removing the cover, an alternative transparent cover with push buttons may be ordered. With the cover in place the user will only have access to the ▼ and TEST/RESET► buttons, allowing all areas of the menu system to be viewed, but preventing setting changes and control actions. The only 'action' that is permitted is to reset the Fault Data display, latched binary outputs and LEDs by using the TEST/RESET ► button.



Figure 1-15 Relay with transparent cover and push buttons

2.4 Power Supply Unit (PSU)

The relay PSU can be ordered with two different nominal power supply ranges

- a) 24V to 60V DC
- b) 80V to 250V DC, 110/115 V rms AC

The rated auxiliary supply voltage (V_x) is clearly stated on the relay fascia rating label, see below.

7SR1 devices manufactured before February 2012, prior to hardware version /CC, cannot be operated from AC supplies and the rating is shown as DC only. From hardware version /CC, devices are available which will operate normally for DC or AC supplies. These 80-250 V DC/110/115 V AC devices of hardware version /CC or later will operate normally for reversed polarity DC auxiliary voltages – devices of previous hardware versions and 24-60V DC devices will not start-up with reversed polarity supplies.

All binary inputs are polarity conscious and will not operate if the DC supply polarity is reversed. For consistency and safety it is advised that AC connections for auxiliary supply and binary inputs are made with the Live connection to the +ve terminal and Neutral connection to –ve.

In the event of the supply voltage level falling below the relay minimum operate level the PSU will automatically switch itself off and latch out – this prevents any PSU overload conditions occurring. The PSU is reset by switching the auxiliary supply off and on.

2.5 Operator Interface/ Fascia

The operator interface is designed to provide a user-friendly method of controlling, entering settings and retrieving data from the relay.



Figure 1-16 Relay with Transparent cover removed

The fascia is an integral part of the relay. Handles are located at each side of the relay which allow it to be withdrawn from the relay case. The relay should not be carried by these handles.

Relay Information

Above the LCD two labels are provided, these provide the following information:

- 1) Product Information & Rating Label, containing
 - Product name
 - MLFB ordering code, with hardware version suffix.
 - Nominal current rating
 - Rated frequency
 - Voltage rating
 - Auxiliary supply rating
 - Binary input supply rating
 - Serial number
- 2) Blank label for user defined information.

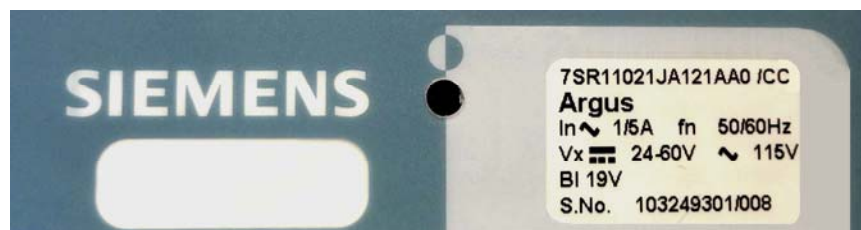

Figure 1-17 Close up of Relay Label

A 'template' is available in Reydisp Software to allow users to create and print customised labels.

For safety reasons the following symbols are displayed on the fascia



Dielectric Test Voltage 2kV



Impulse Test Above 5kV



Caution: Refer to Equipment Documentation



Caution: Risk of Electric Shock

Liquid Crystal Display (LCD)

A 4 line by 20-character alpha-numeric liquid crystal display indicates settings, instrumentation, fault data and control commands.

To conserve power the display backlighting is extinguished when no buttons are pressed for a user defined period. The 'backlight timer' setting within the "SYSTEM CONFIG" menu allows the timeout to be adjusted from 1 to 60 minutes and "Off" (backlight permanently on). After an hour the display is completely de-activated. Pressing any key will re-activate the display.

The LCD contrast can be adjusted using a flat blade screwdriver to turn the screw located below the contrast symbol . Turning the screw clockwise increases the contrast, anti-clockwise reduces the contrast.

User defined indentifying text can be programmed into the relay using the **System config/Relay Identifier and System config/Circuit Identifier** setting. The 'Identifier' texts are displayed on the LCD display, over two lines, at the top level of the menu structure. The 'Relay Identifier' is used in communication with Reydisp to identify the relay. Pressing the Cancel button several times will always return the user to this screen.



Figure 1-18 Close up of Relay Identifier

LCD Indication

General Alarms are user defined text messages displayed on the LCD when mapped to binary or virtual inputs. Up to six general alarms of 16 characters can be programmed, each triggered from one or more input. Each general alarm will also generate an event.

If multiple alarms are activated simultaneously the messages are displayed on a separate page in a rolling display on the LCD. The System Config>**General Alarm Alert** setting **Enabled/Disabled** allows the user to select if the alarms are to be displayed on the LCD when active.

All general alarms raised when a fault trigger is generated will be logged into the Fault Data record.

Standard Keys

The relay is supplied as standard with five pushbuttons. The buttons are used to navigate the menu structure and control relay functions. They are labelled:

▲	Increases a setting or moves up menu.
▼	Decreases a setting or moves down menu.
TEST/RESET▶	Moves right, can be used to reset selected functionality and for LED test (at relay identifier screen).
ENTER	Used to initiate and accept settings changes.
CANCEL	Used to cancel settings changes and/or move up the menu structure by one level per press.

NOTE: All settings and configuration of LEDs, BI and BO can be accessed and set by the user using these keys. Alternatively configuration/settings files can be loaded into the relay using 'Reydisp'. When the System Config>**Setting Dependencies** is ENABLED, only the functions that are enabled will appear in the menu structure.

'PROTECTION HEALTHY' LED

This green LED is steadily illuminated to indicate that DC voltage has been applied to the relay power supply and that the relay is operating correctly. If the internal relay watchdog detects an internal fault then this LED will continuously flash.

Indication LEDs

Relays have 9 user programmable LED indicators. Each LED can be programmed to be illuminated as either green, yellow or red. Where an LED is programmed to be lit both red and green it will illuminate yellow. The same LED can be assigned two different colours dependent upon whether a Start/Pickup or Operate condition exists. LED's can be assigned to the pick up condition and colour selected in the OUTPUT CONFIG>LED CONFIG menu.

Functions are assigned to the LEDs in the OUTPUT CONFIG>OUTPUT MATRIX menu.

Each LED can be labelled by withdrawing the relay and inserting a label strip into the pocket behind the front fascia. A 'template' is available in the Reydisp software tool to allow users to create and print customised legends.

Each LED can be user programmed as hand or self-resetting. Hand reset LEDs can be reset by either pressing the TEST/RESET▶ button, energising a suitably programmed binary input, or, by sending an appropriate command over the data communications channel(s).

The status of hand reset LEDs is maintained by a back up storage capacitor in the event of an interruption to the d.c. supply voltage.



Figure 1-19 LED Indication Label

2.6 Current Inputs

Either one or four current inputs are provided on the Analogue Input module. Terminals are available for both 1A and 5A inputs.

Two types of current input are incorporated within the relay, one type is used for phase fault and earth fault protection, while the other is used for sensitive earth fault (SEF) and restricted earth fault (REF).

Relays with one current input, can be ordered with an earth fault input or a sensitive earth fault input (SEF).

Relays with four current inputs, can be ordered as an earth fault input or a sensitive earth fault input (SEF).

Current is sampled at 1600Hz for both 50Hz and 60Hz system frequencies. Protection and monitoring functions of the relay use either the Fundamental Frequency RMS or the True RMS value of current appropriate to the individual function.

The waveform recorder samples and displays current input waveforms at 1600Hz.

The primary CT ratio used for the relay instruments can be set in the CT/VT configuration menu.

2.7 Voltage Inputs

Three voltage inputs are provided on the Analogue Input module on the 7SR12 relay.

Voltage is sampled at 1600Hz for both 50Hz and 60Hz system frequencies. Protection and monitoring functions of the relay use fundamental frequency voltage measurement.

The waveform recorder samples and displays voltage input waveforms at 1600Hz.

The primary VT ratio used for the relay instruments can be set in the CT/VT configuration menu.

2.8 Binary Inputs

The binary inputs are opto-couplers operated from a suitably rated power supply.

Relays are fitted with 3 or 6 binary inputs (BI) depending on the variant. The user can assign any binary input to any of the available functions (INPUT CONFIG > INPUT MATRIX).

Pick-up (PU) and drop-off (DO) time delays are associated with each binary input. Where no pick-up time delay has been applied the input may pick up due to induced ac voltage on the wiring connections (e.g. cross site wiring). The default pick-up time of 20ms provides ac immunity. Each input can be programmed independently.

Each input may be logically inverted to facilitate integration of the relay within the user scheme. When inverted the relay indicates that the BI is energised when no voltage is applied. Inversion occurs before the PU & DO time delay, see fig. 2.8-1.

Binary inputs can be configured for intentional operation from a 110/115 V rms a.c. power supply by setting of 0ms PU and 25ms DO timers. If additional pickup or drop-off time delays are required by the scheme logic, this functionality can be achieved by programmable logic within the device. For AC operation, live and neutral wiring should be routed as a pair in close proximity and limited to a length of less than 10m. Screened twisted pair cable should be used for routes longer than 10m in length.

Each input may be mapped to any front Fascia indication LED and/or to any Binary output contact and can also be used with the internal user programmable logic. This allows the relay to provide panel indications and alarms.

Each binary input is set by default to be read when the relay is in both the local or remote condition. A setting is provided to allow the user to select if each individual input shall be read when the relay is in the local or remote condition in the INPUT CONFIG > BINARY INPUT CONFIG menu.

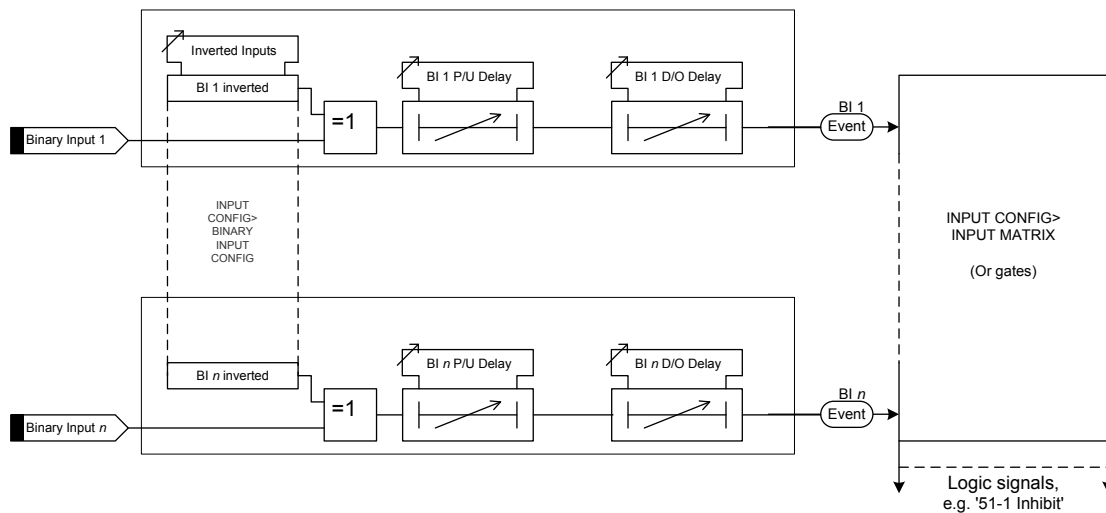

Figure 1-20 Binary Input Logic

2.9 Binary Outputs (Output Relays)

Relays are fitted with 5 or 8 binary outputs (BO). All outputs are fully user configurable and can be programmed to operate from any or all of the available functions.

In the default mode of operation binary outputs are self reset and remain energised for a user configurable minimum time of up to 60 seconds. If required, outputs can be programmed to operate as 'hand reset' or 'pulsed'. If the output is programmed to be 'hand reset' and 'pulsed' then the output will be 'hand reset' only.

Operating a binary output as 'hand reset' fulfils the requirements of ANSI function 86 (Lockout).

The binary outputs can be used to operate the trip coils of the circuit breaker directly where the trip coil current does not exceed the 'make and carry' contact rating. The circuit breaker auxiliary contacts or other in-series auxiliary device must be used to break the trip coil current.

Any BO can be assigned as a 'Trip Contact' in the OUTPUT CONFIG>TRIP CONFIG menu. Operation of a 'Trip Contact' will operate any LED or virtual assigned from the 'Trip Triggered' feature in the same menu and will initiate the fault record storage, actuate the 'Trip Alert' screen where enabled and CB Fail protection when enabled.

Where a protection function is mapped to an output contact, the output contact can be configured to trigger when the protection function picks-up rather than when it operates. Such output contacts are configured via the OUTPUT CONFIG>BINARY OUTPUT CONFIG>Pickup Outputs setting.

Notes on Pulsed Outputs

When operated, the output will reset after a user configurable time of up to 60 seconds regardless of the initiating condition.

Notes on Self Reset Outputs

Self reset operation has a minimum reset time of 100ms

With a failed breaker condition the relay may remain operated until current flow is interrupted by an upstream device. When the current is removed the relay will then reset and attempt to interrupt trip coil current flowing via its output contact. Where this current level is above the break rating of the output contact an auxiliary relay with heavy-duty contacts should be utilised in the primary system to avoid damage to the relay.

Notes on Hand Reset Outputs – 86 Lockout

Any binary output can be programmed to provide an 86 lockout function by selecting it to be hand reset. Hand reset outputs can be reset by either pressing the **TEST/RESET** button, by energising a suitably programmed binary input, or, by sending an appropriate command over the data communications channel(s).

On loss of the auxiliary supply hand-reset outputs will reset. When the auxiliary supply is re-established the binary output will remain in the reset state unless the initiating condition is still present.

Notes on General Pickup

An output, General Pickup, is available to indicate that the pickup level has been exceeded for one or more protection functions. Any protection function can be mapped to trigger this output in the **OUTPUT CONFIG>PICKUP CONFIG** menu.

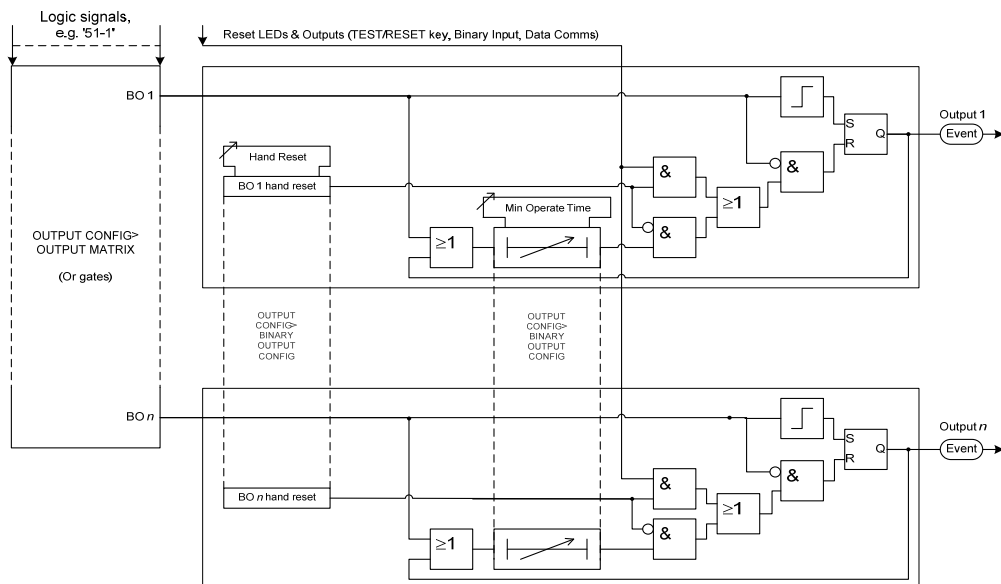

Figure 1-21 Binary Output Logic

2.10 Virtual Input/Outputs

The relays have 8 virtual input/outputs, these are internal binary stores. By assigning the status of data items like starters, alarms, equations etc. to a virtual input/output, the status of these items can be used to fulfil higher levels of functionality.

The status of various data items can be assigned to virtual inputs/outputs using the **INPUT CONFIG > OUTPUT MATRIX** menu.

Virtual input/outputs can be used as inputs to various functions - including blocks, inhibits, triggers, alarms etc. - using the **INPUT CONFIG > INPUT MATRIX** menu.

Virtual input/outputs can also be used as data items in equations.

The status of the virtual inputs and outputs is volatile i.e. not stored during power loss.

2.11 Self Monitoring

The relay incorporates a number of self-monitoring features. Each of these features can initiate a controlled reset recovery sequence.

Supervision includes a power supply watchdog, code execution watchdog, memory checks by checksum and processor/ADC health checks. When all checks indicate the relay is operating correctly the 'Protection Healthy' LED is illuminated.

If an internal failure is detected, a message will be displayed. The relay will reset in an attempt to rectify the failure. This will result in de-energisation of any binary output mapped to 'protection healthy' and flashing of the protection healthy LED. If a successful reset is achieved by the relay the LED and output contact will revert back to normal operational mode, and the relay will restart, therefore ensuring the circuit is protected for the maximum time.

A Start-up Counter Meter is provided to display the number of start-ups the relay has performed. Once the number of start-ups has exceeded a set number, an Alarm output can be given.

```

-----
| Start Alarm          |
| Count                | 1 |
| Target              | 100|
|-----|

```

Figure 1-22 Start-up Counter Meter

Reset of the counter can be done from the meter or via a binary input or a command.

Various types of start-up are monitored by the relay:

1. **power-on starts**
2. **expected starts** (user initiated via comms)
3. **unexpected starts** (caused by the relay watchdog)

Any combination of these can be selected for the start-up count. This is done in the MAINTENANCE MENU>START COUNT menu using the **Start Up Types** setting. All the start-up types selected (ticked) will be added to the overall start-up count.

The number of restarts before the alarm output is raised is set in the MAINTENANCE MENU>START COUNT menu using the **Start Up Count Target** setting.

When the number of relay start-ups reaches the target value an output is raised, OUTPUT MATRIX>**Start Up Count Alarm**, which can be programmed to any combination of binary outputs, LED's or virtual outputs.

The following screen-shot shows the events which are generated when the relay re-starts. The highlighted events show the cause of the re-start. The event which comes next shows the type of restart followed by the relay: Warm, Cold or Re-Start.

2.11.1 Protection Healthy/Defective

When the relay has an auxiliary DC supply and it has successfully passed its self-checking procedure then the front facia Protection Healthy LED is turned on.

A changeover or open contact can be mapped via the binary output matrix to provide an external protection healthy signal.

A changeover or closed contact can be mapped via the binary output matrix to provide an external protection defective signal. With the 'Protection Healthy' this contact is open. When the auxiliary DC supply is not applied to the relay or a problem is detected within the relay then this output contact closes to provide external indication.

If the relay is withdrawn from the case, the case shorting contact will make across the normally closed contacts to provide an external alarm.

The screenshot shows the 'Keydisp Evolution' application window. The main area displays a table of events under the 'Event Record' tab. The table has four columns: Time, Type, Action, and Description. The events are listed chronologically, showing a sequence of power-on, restart, and fault events.

Time	Type	Action	Description
08:24:33.820,19/10/2011	60	Raised	Clear Event Records
08:25:08.500,19/10/2011	160	Raised	Power On
	60	Raised	Re-Start
	160	Raised	Setting G1 selected
08:25:16.505,19/10/2011	183	Raised	E/F Out
08:25:16.555,19/10/2011	60	Raised	Local & Remote
08:26:23.500,19/10/2011	60	Raised	Expected Restart
	60	Raised	Re-Start
	160	Raised	Setting G1 selected
08:26:31.505,19/10/2011	183	Raised	E/F Out
08:26:31.555,19/10/2011	60	Raised	Local & Remote
08:27:25.500,19/10/2011	60	Raised	Unexpected Restart
	60	Raised	Re-Start
	160	Raised	Setting G1 selected
08:27:33.505,19/10/2011	183	Raised	E/F Out
08:27:33.555,19/10/2011	60	Raised	Local & Remote

Address 1 : 7SR1206-4xA12-xCA0 : 7SR12

Address 1 @ COM1:38400,n

Figure 1-23 Start-up Events

Section 3: Protection Functions

3.1 Current Protection: Phase Overcurrent (67, 51, 50)

All phase overcurrent elements have a common setting for the 50 elements and 51 elements to measure either fundamental frequency RMS or True RMS current:

True RMS current: **50 Measurement = RMS, 51 Measurement = RMS**

Fundamental Frequency RMS current: **50 Measurement = Fundamental, 51 Measurement = Fundamental**

3.1.1 Directional Control of Overcurrent Protection (67) – 7SR12

The directional element produces forward and reverse outputs for use with overcurrent elements. These outputs can then be mapped as controls to each shaped and instantaneous over-current element.

If a protection element is set as non-directional then it will operate independently of the output of the directional detector. However, if a protection element is programmed for forward directional mode then operation will occur only for a fault lying within the forward operate zone. Conversely, if a protection element is programmed for reverse directional mode then operation will occur only for a fault lying within the reverse operate zone. Typically the forward direction is defined as being 'away' from the busbar or towards the protected zone.

The Characteristic angle is the phase angle by which the polarising voltage must be adjusted such that the directional detector gives maximum sensitivity in the forward operate zone when the current is in phase with it. The reverse operate zone is the mirror image of the forward zone.

Voltage polarisation is achieved for the phase-fault elements using the quadrature voltage i.e. at unity power factor I leads V by 90°. Each phase current is compared to the voltage between the other two phases:

$$I_{L1} \sim V_{23} \quad I_{L2} \sim V_{31} \quad I_{L3} \sim V_{12}$$

The characteristic angle can be user programmed to any angle between -95° and +95° using the **67 Char Angle** setting. The voltage is the reference phasor (V_{ref}) and the **67 Char Angle** setting is added to this to adjust the forward and reverse zones.

The centre of the forward zone is set by (V_{ref} Angle + **67 Char Angle**) and should be set to correspond with I_{fault} Angle for maximum sensitivity i.e.

For fault current of -60° (I lagging V by 60°) a **67 Char Angle** of **+30°** is required for maximum sensitivity (i.e. due to quadrature connection $90^\circ - 60^\circ = 30^\circ$).

OR

For fault current of -45° (I lagging V by 45°) a **67 Char Angle** of **+45°** is required for maximum sensitivity (i.e. due to quadrature connection $90^\circ - 45^\circ = 45^\circ$).

Two-out-of-three Gate

When the **67 2-Out-Of-3 Logic** setting is set to **Enabled**, the directional elements will only operate for the majority direction, e.g. if I_{L1} and I_{L3} are detected as forward flowing currents and I_{L2} is detected as reverse current flow, phases L_1 and L_3 will operate forwards, while phase L_2 will be inhibited.

Minimum Polarising Voltage

The **67 Minimum Voltage** setting defines the minimum polarising voltage level. Where the measured polarising voltage is below this level no directional control signal is given and operation of protection elements set as directional will be inhibited. This prevents mal-operation under fuse failure/MCB tripped conditions where noise voltages can be present.

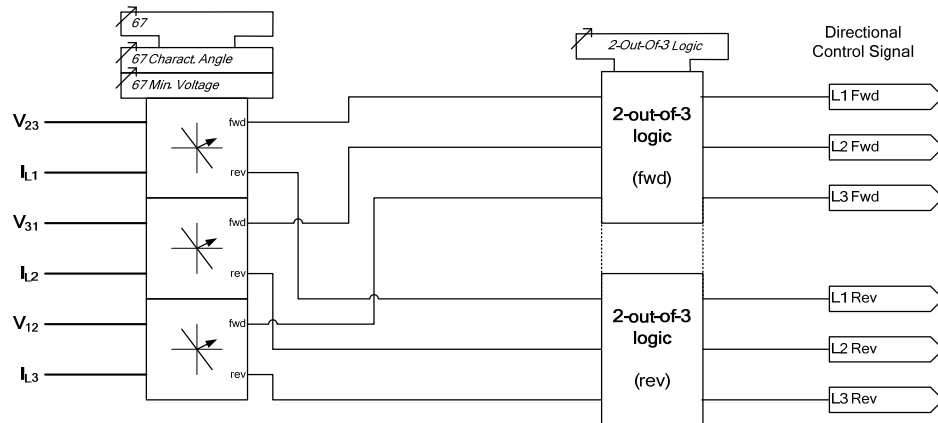

Figure 1-24 Logic Diagram: Directional Overcurrent Element (67)

3.1.2 Instantaneous Overcurrent Protection (50)

Two Instantaneous overcurrent elements are provided in the 7SR11 relay and four elements are provided in the 7SR12 relay.

50-1, 50-2, (50-3 & 50-4 – 7SR12)

Each instantaneous element (50-n) has independent settings. **50-n Setting** for pick-up current and **50-n Delay** follower time delay. The instantaneous elements have transient free operation.

Where directional elements are present the direction of operation can be set using **50-n Dir. Control** setting. Directional logic is provided independently for each 50-n element, e.g. giving the option of using two elements set to forward and two to reverse.

Operation of the instantaneous overcurrent elements can be inhibited from:

Inhibit 50-n	A binary or virtual input.
79 P/F Inst Trips: 50-n	When 'delayed' trips only are allowed in the auto-reclose sequence (79 P/F Prot'n Trip n = Delayed).
50-n Inrush Action: Block	Operation of the inrush current detector function.
50-n VTS Action: Inhibit	Operation of the VT Supervision function (7SR1205 & 7SR1206).

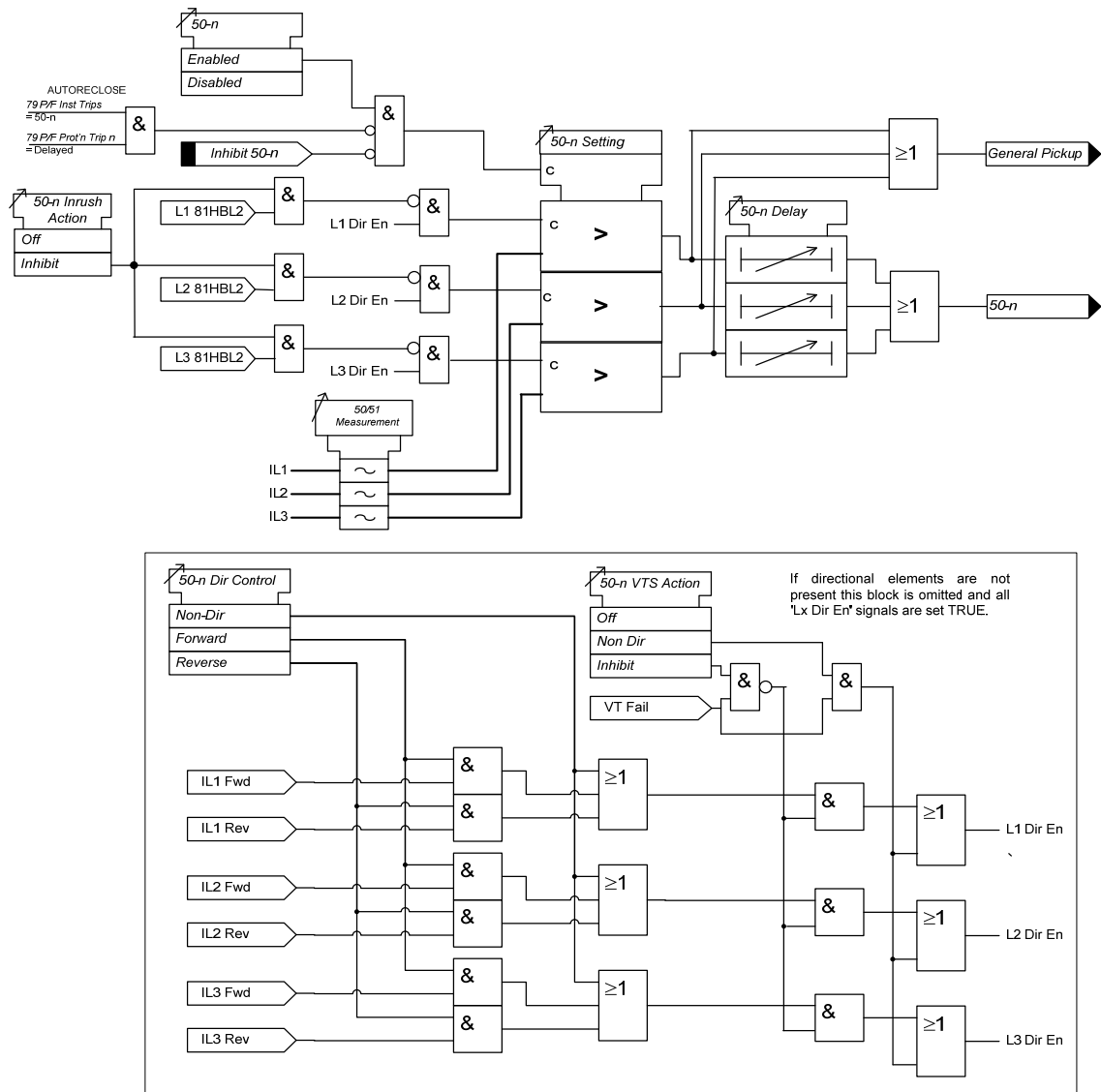

Figure 1-25 Logic Diagram: Instantaneous Over-current Element

3.1.3 Time Delayed Overcurrent Protection (51)

Two time delayed overcurrent elements are provided in the 7SR11 relay and four elements are provided in the 7SR12 relay.

51-1, 51-2, (51-3 & 51-4 – 7SR12)

51-n Setting sets the pick-up current level. Where the voltage controlled overcurrent function (51VCO) is used a multiplier is applied to this setting where the voltage drops below the setting **VCO Setting**, see Section 3.2.

A number of shaped characteristics are provided. An inverse definite minimum time (IDMT) characteristic is selected from IEC, ANSI or user specific curves using **51-n Char**. A time multiplier is applied to the characteristic curves using the **51-n Time Mult** setting. Alternatively, a definite time lag delay (DTL) can be chosen using **51-n Char**. When Definite Time Lag (DTL) is selected the time multiplier is not applied and the **51-n Delay (DTL)** setting is used instead. The full list of operating curves is given in Chapter 2 – ‘Settings and Instruments Guide’. Operating curve characteristics are illustrated in Chapter 3 – ‘Performance Specification’.

The **51-n Reset** setting can apply a **definite time delayed** reset, or when the operation is configured as an IEC or ANSI or user characteristic if the reset is selected as **(IEC/ANSI) DECAYING** reset the associated reset curve will be used. The reset mode is significant where the characteristic has reset before issuing a trip output – see ‘Applications Guide’.

A minimum operate time for the characteristic can be set using **51-n Min. Operate Time** setting.

A fixed additional operate time can be added to the characteristic using **51-n Follower DTL** setting.

Where directional elements are present the direction of operation can be set using **51-n Dir. Control** setting. Directional logic is provided independently for each 51-n element

Operation of the time delayed overcurrent elements can be inhibited from e.g. giving the option of using two elements set to forward and two to reverse.

- Inhibit 51-n** A binary or virtual input.
- 79 P/F Inst Trips: 51-n** When 'delayed' trips only are allowed in the auto-reclose sequence (**79 P/F Prot'n Trip n = Delayed**).
- 51c** Activation of the cold load settings.
- 50-n Inrush Action: Block** Operation of the inrush current detector function.
- 51-n VTSAction: Inhibit** Operation of the VT Supervision function (7SR1205 & 7SR1206).

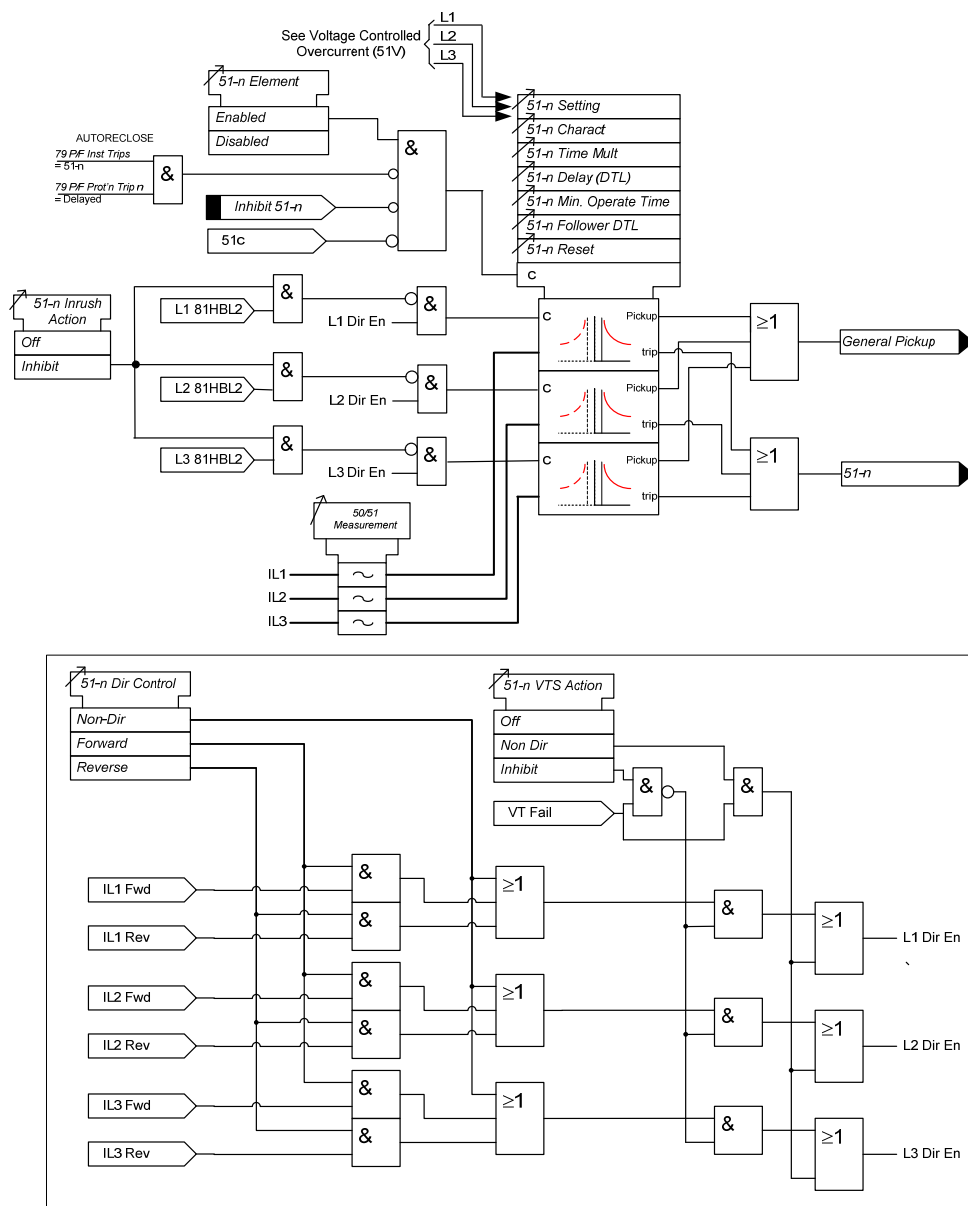

Figure 1-26 Logic Diagram: Time Delayed Overcurrent Element

3.1.4 Current Protection: Voltage Controlled Overcurrent (51V) - 7SR12

Voltage controlled overcurrent is only available in relays with four current inputs.

Each shaped overcurrent element **51-n Setting** can be independently controlled by the level of measured (control) input voltage.

For applied voltages above **VCO Setting** the 51-n element operates in accordance with its normal current setting (see 3.1.3). For input Ph-Ph control voltages below **VCO Setting** a multiplier (**51-n Multiplier**) is applied to reduce the 51-n pickup current setting.

51-n Multiplier is applied to each phase independently when its control phase-phase voltage falls below **VCO Setting**. The voltage levels used for each phase over-current element are shown in the table below. Relays with a Ph-N connection automatically calculate the correct Ph-Ph control voltage.

Current Element	Control Voltage
I_{L1}	V_{12}
I_{L2}	V_{23}
I_{L3}	V_{31}

The Voltage Controlled Overcurrent function (51V) can be inhibited from:

VCO VTSAction: Inhibit

Operation of the VT Supervision function.

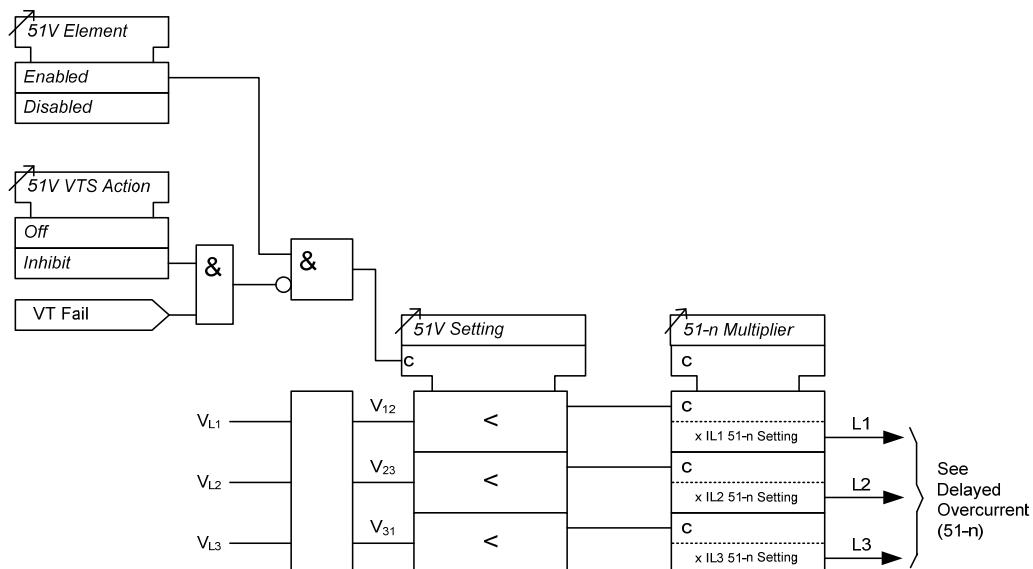

Figure 1-27 Logic Diagram: Voltage Controlled Overcurrent Protection

3.2 Current Protection: Derived Earth Fault (67N, 51N, 50N)

The earth current is derived by calculating the sum of the measured line currents. The elements measure the fundamental frequency RMS current.

3.2.1 Directional Control of Derived Earth Fault Protection (67N) – 7SR12

The directional element produces forward and reverse outputs for use with derived earth fault elements. These outputs can be mapped as controls to each shaped and instantaneous element.

If a protection element is set as non-directional then it will operate independently of the output of the directional detector. However, if a protection element is programmed for forward directional mode then operation will occur only for a fault lying within the forward operate zone. Conversely, if a protection element is programmed for reverse directional mode then operation will occur only for a fault lying within the reverse operate zone. Typically the forward direction is defined as being 'away' from the busbar or towards the protected zone.

The Characteristic angle is the phase angle by which the polarising voltage must be adjusted such that the directional detector gives maximum sensitivity in the forward operate zone when the current is in phase with it. The reverse operate zone is the mirror image of the forward zone.

The derived directional earth fault elements can use either zero phase sequence (ZPS) or negative phase sequence (NPS) polarising. This is selected using the **67N Polarising Quantity** setting. Whenever a zero-sequence voltage is available (a five-limb VT that can provide a zero sequence path or an open-delta VT connection) the earth-fault element can use zero-sequence voltage and current for polarisation. If zero-sequence polarising voltage is not available e.g. when a two phase (phase to phase) connected VT is installed, then negative-sequence voltage and negative-sequence currents must be used. The type of VT connection is specified by **Voltage Config** (CT/VT CONFIG menu). Settings advice is given in the Applications Guide.

Voltage polarisation is achieved for the earth-fault elements by comparison of the appropriate current with its equivalent voltage:

$$\text{67N Polarising Quantity: ZPS} \quad I_0 \sim V_0$$

$$\text{67N Polarising Quantity: NPS} \quad I_2 \sim V_2$$

The characteristic angle can be user programmed to any angle between -95° and $+95^\circ$ using the **67N Char Angle** setting. The voltage is the reference phasor (V_{ref}) and the **67N Char Angle** setting is added to this to adjust the forward and reverse zones.

The centre of the forward zone is set by (V_{ref} Angle + **67N Char Angle**) and should be set to correspond with I_{fault} Angle for maximum sensitivity e.g.

For fault current of -15° (I lagging V by 15°) a **67N Char Angle** of -15° is required for maximum sensitivity.

OR

For fault current of -45° (I lagging V by 45°) a **67 Char Angle** of -45° is required for maximum sensitivity.

Minimum Polarising Voltage

The **67N Minimum Voltage** setting defines the minimum polarising voltage level. Where the measured polarising voltage is below this level no directional output is given and operation of protection elements set as directional will be inhibited. This prevents mal-operation under fuse failure/MCB tripped conditions where noise voltages can be present.

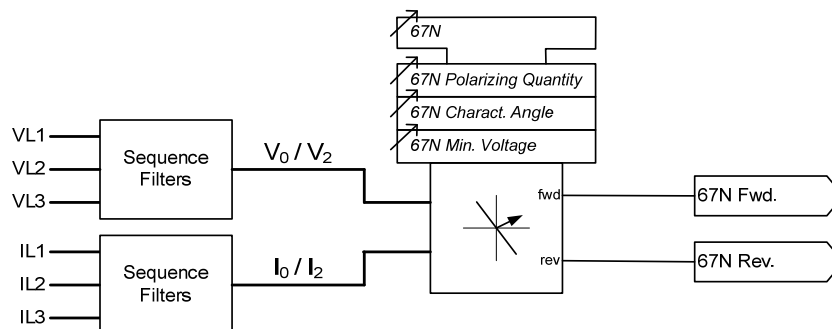

Figure 1-28 Logic Diagram: Derived Directional Earth Fault Element

3.2.2 Instantaneous Derived Earth Fault Protection (50N)

Two instantaneous derived earth fault elements are provided in the 7SR11 relay and four elements are provided in the 7SR12 relay.

50N-1, 50N-2, (50N-3 & 50N-4 – 7SR12)

Each instantaneous element has independent settings for pick-up current **50N-n Setting** and a follower time delay **50N-n Delay**. The instantaneous elements have transient free operation.

Where directional elements are present the direction of operation can be set using **50N-n Dir. Control** setting. Directional logic is provided independently for each 50-n element.

Operation of the instantaneous earth fault elements can be inhibited from:

Inhibit 50N-n	A binary or virtual input.
79 E/F Inst Trips: 50N-n	When 'delayed' trips only are allowed in the auto-reclose sequence (79 E/F Prot'n Trip n = Delayed).
50-n Inrush Action: Block	Operation of the inrush current detector function.
50N-n VTSAction: Inhibit	Operation of the VT Supervision function (7SR1205 & 7SR1206).

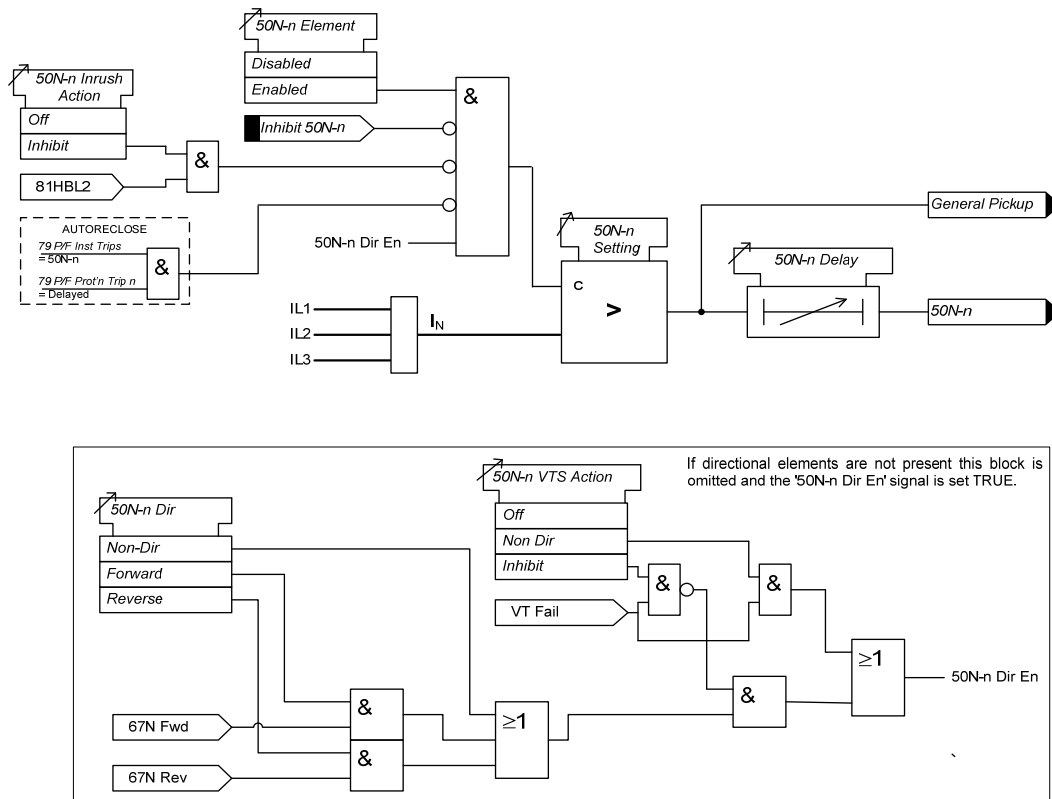

Figure 1-29 Logic Diagram: Derived Instantaneous Earth Fault Element

3.2.3 Time Delayed Derived Earth Fault Protection (51N)

Two time delayed derived earth fault elements are provided in the 7SR11 relay and four elements are provided in the 7SR12 relay.

51N-1, 51N-2, (51N-3 & 51N-4 – 7SR12)

51N-n Setting sets the pick-up current level.

A number of shaped characteristics are provided. An inverse definite minimum time (IDMT) characteristic is selected from IEC and ANSI curves using **51N-n Char**. A time multiplier is applied to the characteristic curves using the **51N-n Time Mult** setting. Alternatively, a definite time lag delay (DTL) can be chosen using **51N-n**

Char. When definite time lag (DTL) is selected the time multiplier is not applied and the **51N-n Delay (DTL)** setting is used instead.

The **51-n Reset** setting can apply a **definite time delayed** reset, or when the operation is configured as an IEC or ANSI or user characteristic if the reset is selected as **IEC/ANSI (DECAYING)** reset the associated reset curve will be used. The reset mode is significant where the characteristic has reset before issuing a trip output – see 'Applications Guide'

A minimum operate time for the characteristic can be set using the **51N-n Min. Operate Time** setting.

A fixed additional operate time can be added to the characteristic using the **51N-n Follower DTL** setting.

Where directional elements are present the direction of operation can be set using **51N-n Dir. Control** setting. Directional logic is provided independently for each 51N-n element.

Operation of the time delayed earth fault elements can be inhibited from:

- Inhibit 51N-n** A binary or virtual input.
- 79 E/F Inst Trips: 51N-n** When 'delayed' trips only are allowed in the auto-reclose sequence (**79 E/F Prot'n Trip n = Delayed**).
- 50-n Inrush Action: Block** Operation of the inrush current detector function.
- 51N-n VTSAction: Inhibit** Operation of the VT Supervision function (7SR1205 & 7SR1206).

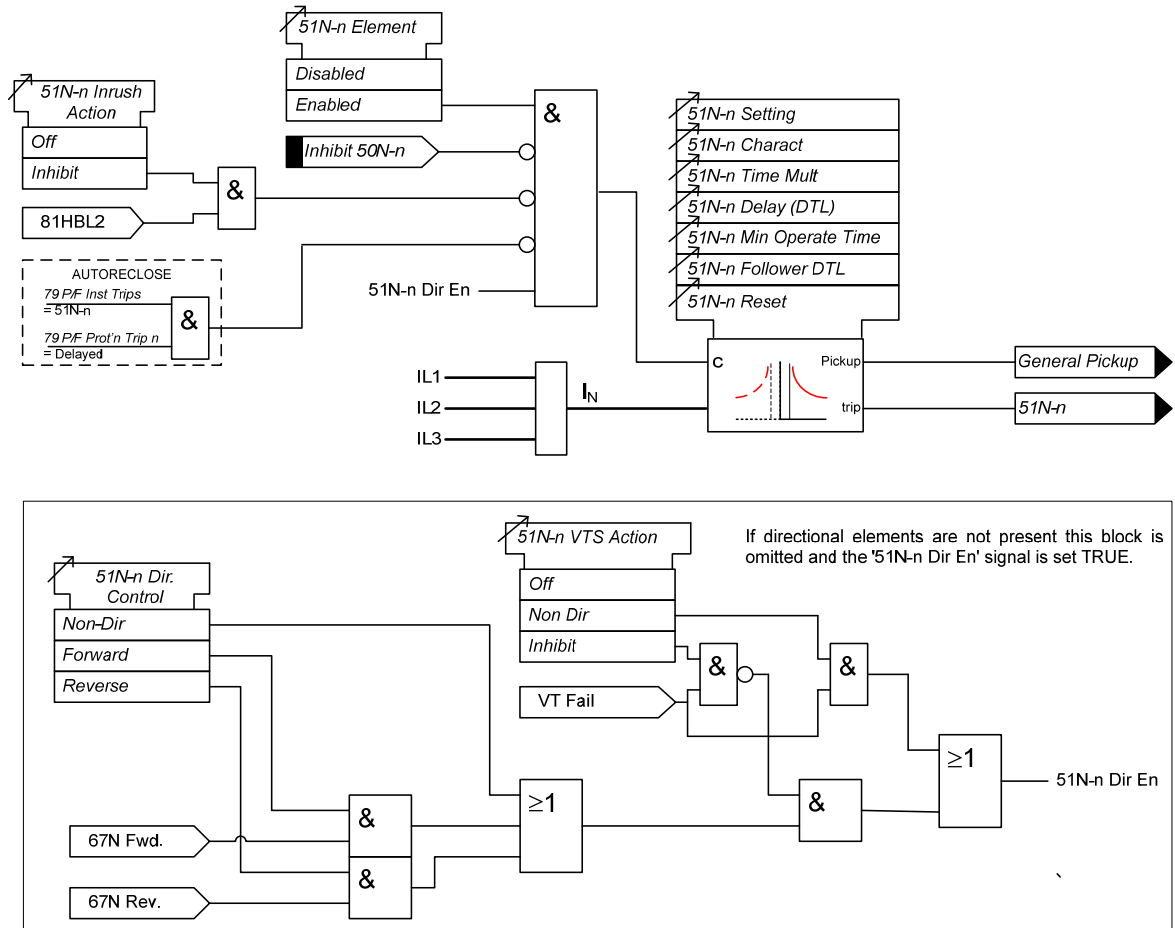

Figure 1-30 Logic Diagram: Derived Time Delayed Earth Fault Protection

3.3 Current Protection: Measured Earth Fault (67G, 51G, 50G)

The earth current is measured directly via a dedicated current analogue input, IL4.

All measured earth fault elements have a common setting to measure either fundamental frequency RMS or True RMS current:

True RMS current: **50 Measurement = RMS, 51 Measurement = RMS**

Fundamental Frequency RMS current: **50 Measurement = Fundamental, 51 Measurement = Fundamental**

3.3.1 Directional Control of Measured Earth Fault Protection (67G) – 7SR12

The directional element produces forward and reverse outputs for use with measured earth fault elements. These outputs can be mapped as controls to each shaped and instantaneous element.

If a protection element is set as non-directional then it will operate independently of the output of the directional detector. However, if a protection element is programmed for forward directional mode then operation will occur only for a fault lying within the forward operate zone. Conversely, if a protection element is programmed for reverse directional mode then operation will occur only for a fault lying within the reverse operate zone. Typically the forward direction is defined as being 'away' from the busbar or towards the protected zone.

The Characteristic angle is the phase angle by which the polarising voltage must be adjusted such that the directional detector gives maximum sensitivity in the forward operate zone when the current is in phase with it. The reverse operate zone is the mirror image of the forward zone.

The measured directional earth fault elements use zero phase sequence (ZPS) polarising.

Voltage polarisation is achieved for the earth-fault elements by comparison of the appropriate current with its equivalent voltage:

$$I_0 \sim V_0$$

The characteristic angle can be user programmed to any angle between -95° and $+95^\circ$ using the **67G Char Angle** setting. The voltage is the reference phasor (V_{ref}) and the **67G Char Angle** setting is added to this to adjust the forward and reverse zones.

The centre of the forward zone is set by (V_{ref} Angle + **67G Char Angle**) and should be set to correspond with I_{fault} Angle for maximum sensitivity e.g.

For fault current of -15° (I lagging V by 15°) a **67G Char Angle** of -15° is required for maximum sensitivity, OR

For fault current of -45° (I lagging V by 45°) a **67G Char Angle** of -45° is required for maximum sensitivity.

Minimum Polarising Voltage

The **67G Minimum Voltage** setting defines the minimum polarising voltage level. Where the measured polarising voltage is below this level no directional output is given and. Operation of protection elements set as directional will be inhibited. This prevents mal-operation under fuse failure/MCB tripped conditions where noise voltages can be present.

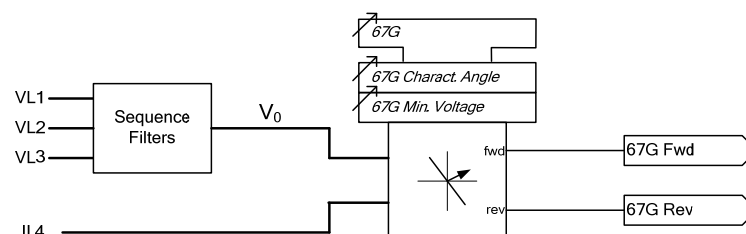

Figure 1-31 Logic Diagram: Measured Directional Earth Fault Protection

3.3.2 Instantaneous Measured Earth Fault Protection (50G)

Two instantaneous derived earth fault elements are provided in the 7SR11 relay and four elements are provided in the 7SR12 relay.

50G-1, 50G-2, (50G-3 & 50G-4 – 7SR12)

Each instantaneous element has independent settings for pick-up current **50G-n Setting** and a follower time delay **50G-n Delay**. The instantaneous elements have transient free operation.

Where directional elements are present the direction of operation can be set using **50G-n Dir. Control** setting. Directional logic is provided independently for each 50G-n element e.g. giving the option of using two elements set to forward and two to reverse.

Operation of the instantaneous measured earth fault elements can be inhibited from:

- Inhibit 50G-n** A binary or virtual input.
- 79 E/F Inst Trips: 50G-n** When 'delayed' trips only are allowed in the auto-reclose sequence (**79 E/F Prot'n Trip n = Delayed**).
- 50-n Inrush Action: Block** Operation of the inrush current detector function.
- 50G-n VTSAction: Inhibit** Operation of the VT Supervision function (7SR1205 & 7SR1206).

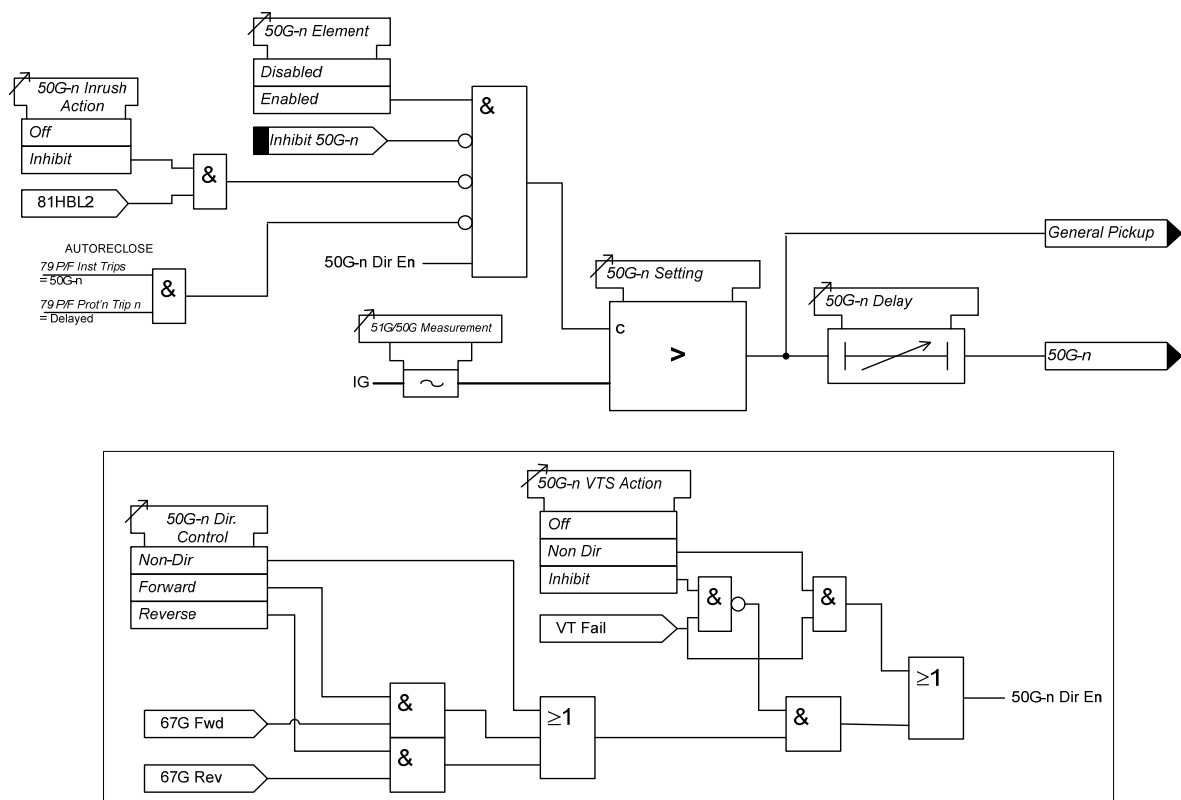

Figure 1-32 Logic Diagram: Measured Instantaneous Earth-fault Element

3.3.3 Time Delayed Measured Earth Fault Protection (51G)

Two instantaneous derived earth fault elements are provided in the 7SR11 relay and four elements are provided in the 7SR12 relay.

51G-1, 51G-2, (51G-3 & 51G-4 – 7SR12)

51G-n Setting sets the pick-up current level.

A number of shaped characteristics are provided. An inverse definite minimum time (IDMT) characteristic is selected from IEC and ANSI curves using **51G-n Char**. A time multiplier is applied to the characteristic curves using the **51G-n Time Mult** setting. Alternatively, a definite time lag (DTL) can be chosen using **51G-n Char**. When DTL is selected the time multiplier is not applied and the **51G-n Delay (DTL)** setting is used instead. The full list of operating curves is given in Section 2 – ‘Settings, Configuration and Instruments Guide’. Operating curve characteristics are illustrated in Section 3 – ‘Performance Specification’.

The **51-n Reset** setting can apply a **definite time delayed** reset, or when the operation is configured as an IEC or ANSI or user characteristic if the reset is selected as **IEC/ANSI (DECAYING)** reset the associated reset curve will be used. The reset mode is significant where the characteristic has reset before issuing a trip output – see ‘Applications Guide’

A minimum operate time for the characteristic can be set using **51G-n Min. Operate Time** setting.

A fixed additional operate time can be added to the characteristic using **51G-n Follower DTL** setting.

Where directional elements are present the direction of operation can be set using **51G-n Dir. Control** setting. Directional logic is provided independently for each 51G-n element e.g. giving the option of using two elements set to forward and two to reverse.

Operation of the time delayed measured earth fault elements can be inhibited from:

- Inhibit 51G-n** A binary or virtual input.
- 79 E/F Inst Trips: 51G-n (79 E/F Prot'n Trip n = Delayed).** When ‘delayed’ trips only are allowed in the auto-reclose sequence
- 50-n Inrush Action: Block** Operation of the inrush current detector function.
- 51G-n VTSAction: Inhibit** Operation of the VT Supervision function (7SR1205 & 7SR1206).

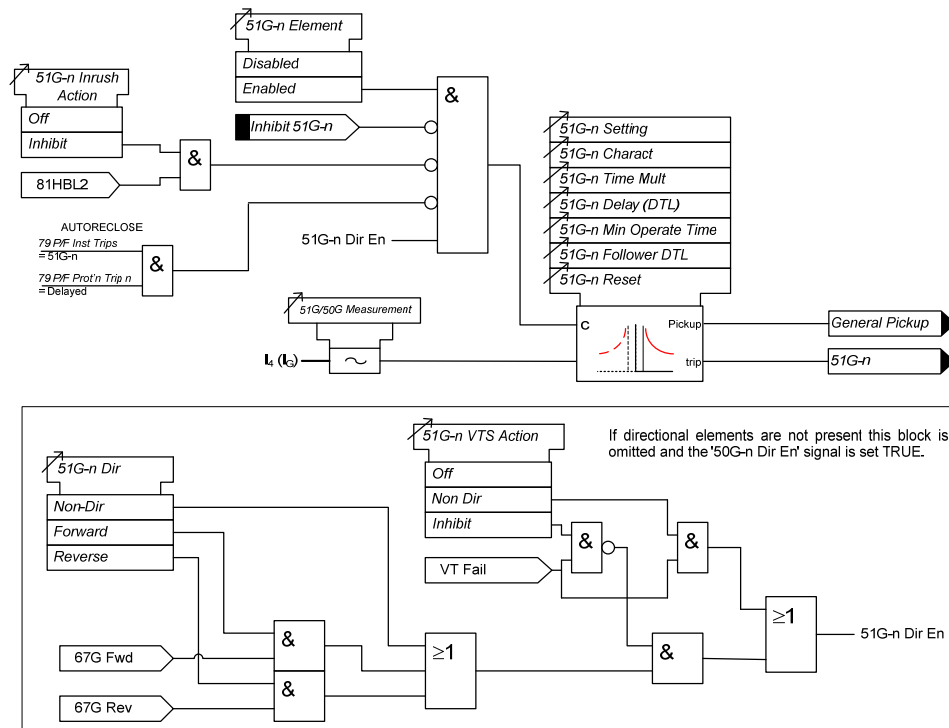

Figure 1-33 Logic Diagram: Measured Time Delayed Earth Fault Element (51G)

3.4 Current Protection: Sensitive Earth Fault (67SEF, 51SEF, 50SEF)

Current for the Sensitive Earth Fault (SEF) elements is measured directly via a dedicated current analogue input which requires different hardware that must be specially ordered. SEF elements measure the fundamental frequency RMS current.

3.4.1 Directional Control of Sensitive Earth Fault Protection (67SEF) – 7SR12

The directional element produces forward and reverse outputs for use with SEF elements. These outputs can be mapped as controls to each shaped and instantaneous element.

If a protection element is set as non-directional then it will operate independently of the output of the directional detector. However, if a protection element is programmed for forward directional mode then operation will occur only for a fault lying within the forward operate zone. Conversely, if a protection element is programmed for reverse directional mode then operation will occur only for a fault lying within the reverse operate zone. Typically the forward direction is defined as being 'away' from the busbar or towards the protected zone.

The forward directional zone of the relay is defined by the characteristic angle setting which is the angle by which the polarising voltage differs from the operating current. The forward directional zone is symmetrical around the characteristic angle with angular limits defined in the performance specification. The reverse operate zone is the mirror image of the forward zone.

The directional sensitive earth fault elements use zero phase sequence (ZPS) polarising.

Voltage polarisation is achieved for the earth-fault elements by comparison of the appropriate current with its equivalent voltage:

$$I_0 \sim V_0$$

The characteristic angle can be user programmed to any angle between -95° and $+95^\circ$ using the **67SEF Char Angle** setting. The voltage is the reference phasor (V_{ref}) and the **67SEF Char Angle** setting is added to this to adjust the forward and reverse zones.

The centre of the forward zone is set by (V_{ref} Angle + **67SEF Char Angle**) and should be set to correspond with I_{fault} Angle for maximum sensitivity i.e.

For fault current of -15° (I lagging V by 15°) a **67SEF Char Angle** of -15° is required for maximum sensitivity.

OR

For fault current of -45° (I lagging V by 45°) a **67SEF Char Angle** of -45° is required for maximum sensitivity.

For resonant grounded systems where compensation (Petersen) coils are fitted, earth fault current is deliberately reduced to zero and therefore is difficult to measure for protection purposes. However, the wattmetric component in the capacitive charging currents, which are close to the directional zone boundary, can be used to indicate fault location. It is advantageous to increase the directional limits towards $\pm 90^\circ$ so that the directional boundary can be used to discriminate between faulted and healthy circuits. A **67SEF Compensated Network Enable** user setting is provided to provide this feature for use with compensated networks only.

Minimum Polarising Voltage

The **67SEF Minimum Voltage** setting defines the minimum polarising voltage level. Where the measured polarising voltage is below this level no directional output is given and. Operation of protection elements set as directional will be inhibited. This prevents mal-operation under fuse failure/MCB tripped conditions where noise voltages can be present.

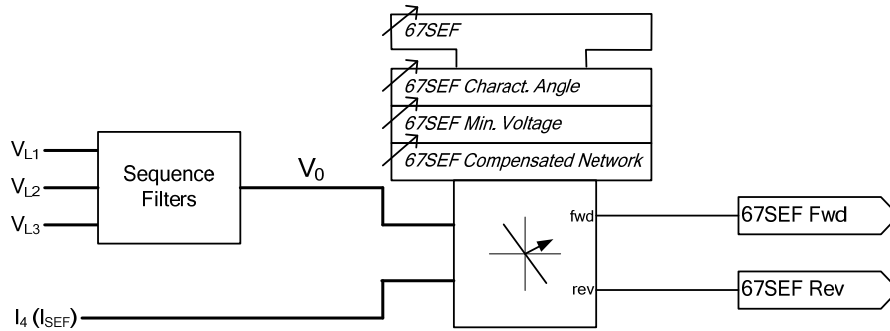

Figure 1-34 Logic Diagram: SEF Directional Element (67SEF)

3.4.2 Instantaneous Sensitive Earth Fault Protection (50SEF)

Two sensitive earth fault elements are provided in the 7SR11 relay and four elements are provided in the 7SR12 relay.

50SEF-1, 50SEF-2, (50SEF-3 & 50SEF-4– 7SR12)

Each instantaneous element has independent settings for pick-up current **50SEF-n Setting** and a follower time delay **50SEF-n Delay**. The instantaneous elements have transient free operation.

Where directional elements are present the direction of operation can be set using **50SEF-n Dir. Control** setting. Directional logic is provided independently for each 50SEF-n element e.g. giving the option of using two elements set to forward and two to reverse.

Operation of the instantaneous earth fault elements can be inhibited from:

Inhibit 50SEF-n	A binary or virtual input.
79 SEF Inst Trips: 50SEF-n	When 'delayed' trips only are allowed in the auto-reclose sequence (79 SEF Prot'n Trip n = Delayed).
50SEF-n VTSAction: Inhibit	Operation of the VT Supervision function (7SR1205 & 7SR1206).

Directional elements will not operate unless the zero sequence voltage (V_0) is above the **67SEF Minimum Voltage** setting i.e. the residual voltage is greater than 3 times this setting and the phase is in the Forward/Reverse operating range. If **67SEF Wattmetric** is set to Enabled, the calculated residual real power must be above the **67SEF Wattmetric Power** setting for any SEF element operation. The residual power P_{res} is equal to the wattmetric component of $3V_0I_{SEF}$ and therefore the wattmetric component of $9V_0I_0$.

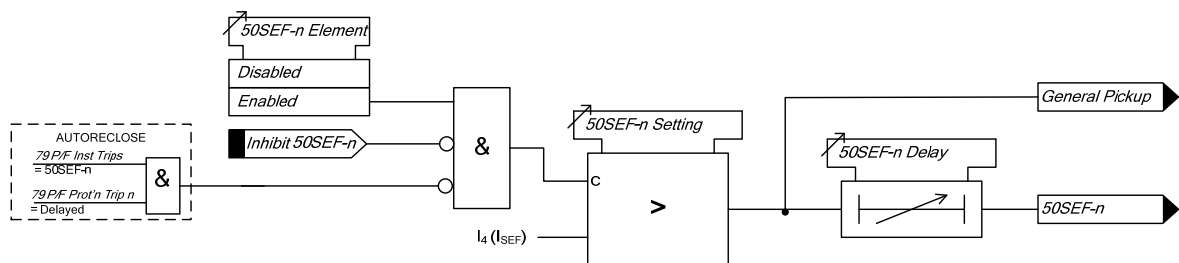

Figure 1-35 Logic Diagram: 7SR11 SEF Instantaneous Element

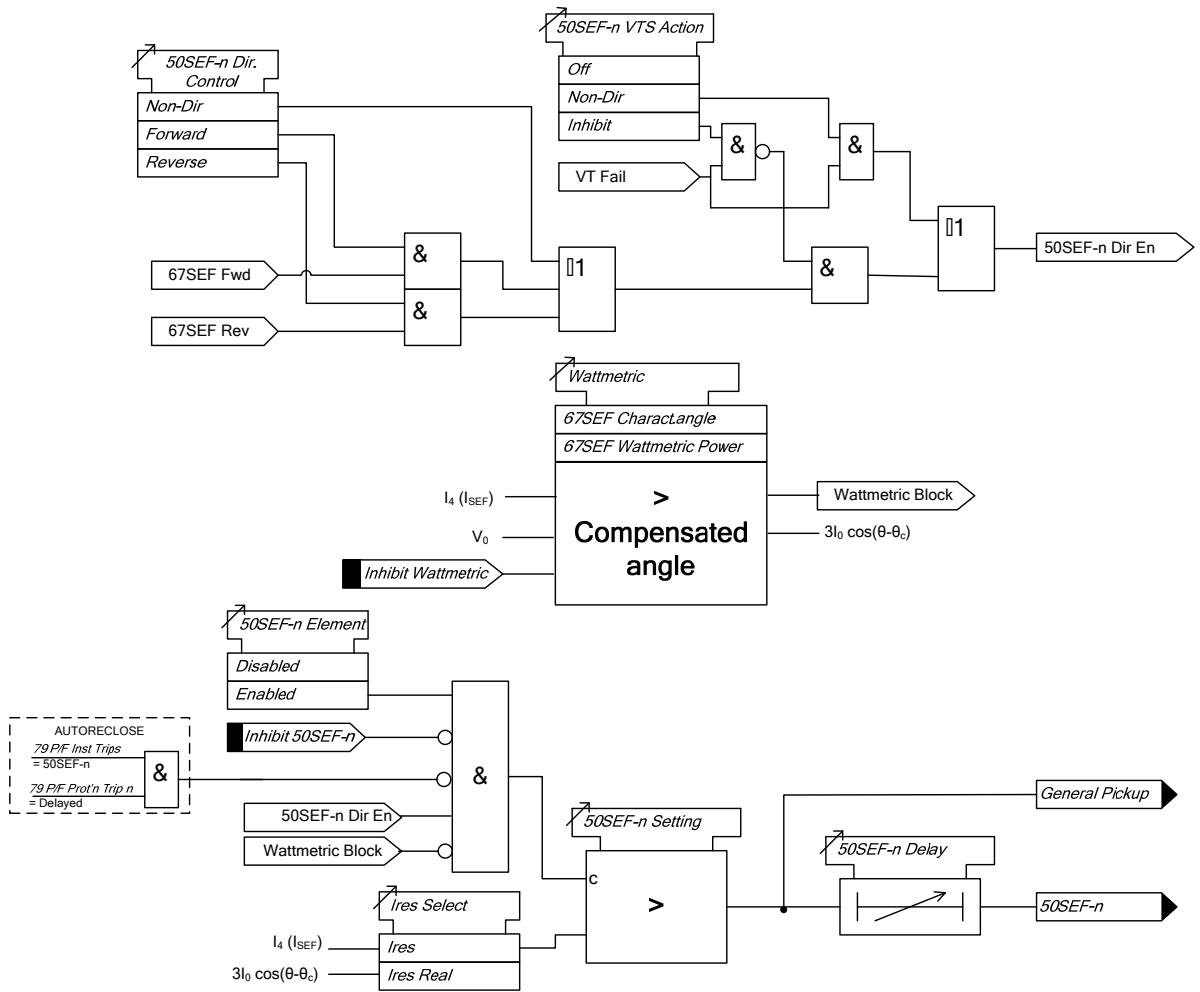

Figure 1-36 Logic Diagram: 7SR12 SEF Instantaneous Element

3.4.3 Time Delayed Sensitive Earth Fault Protection (51SEF)

Two sensitive earth fault elements are provided in the 7SR11 relay and four elements are provided in the 7SR12 relay.

51SEF-1, 51SEF-2, (51SEF-3 & 51SEF-4– 7SR12)

51SEF-n Setting sets the pick-up current level.

A number of shaped characteristics are provided. An inverse definite minimum time (IDMT) characteristic is selected from IEC and ANSI curves using **51SEF-n Char**. A time multiplier is applied to the characteristic curves using the **51SEF-n Time Mult** setting. Alternatively, a definite time lag (DTL) can be chosen using **51SEF-n Char**. When DTL is selected the time multiplier is not applied and the **51SEF-n Delay (DTL)** setting is used instead.

The **51SEF-n Reset** setting can apply a **definite time delayed** reset, or when configured as an IEC or ANSI characteristic an **IEC/ANSI (DECAYING)** reset. The reset mode is significant where the characteristic has reset before issuing a trip output – see ‘Applications Guide’.

A minimum operate time for the characteristic can be set using **51SEF-n Min. Operate Time** setting.

A fixed additional operate time can be added to the characteristic using **51SEF-n Follower DTL** setting.

Where directional elements are present the direction of operation can be set using **51SEF-n Dir. Control** setting. Directional logic is provided independently for each 51SEF-n element e.g. giving the option of using two elements set to forward and two to reverse.

Operation of the time delayed earth fault elements can be inhibited from:

Inhibit 51SEF-n A binary or virtual input

79 SEF Inst Trips: 51SEF-n When ‘delayed’ trips only are allowed in the auto-reclose sequence (**79 SEF Prot’n Trip n = Delayed**).

51SEF-n VTSAction: Inhibit Operation of the VT Supervision function (7SR1205 & 7SR1206).

Directional elements will not operate unless the zero sequence voltage (V_0) is above the **67SEF Minimum Voltage** setting i.e. the residual voltage is greater than 3 times this setting and the phase is in the Forward/Reverse operating range. If **67SEF Wattmetric** is set to Enabled, the calculated residual real power must be above the **67SEF Wattmetric Power** setting. The residual power P_{res} is equal to the wattmetric component of $3V_0I_{SEF}$ and therefore the wattmetric component of $9V_0I_0$

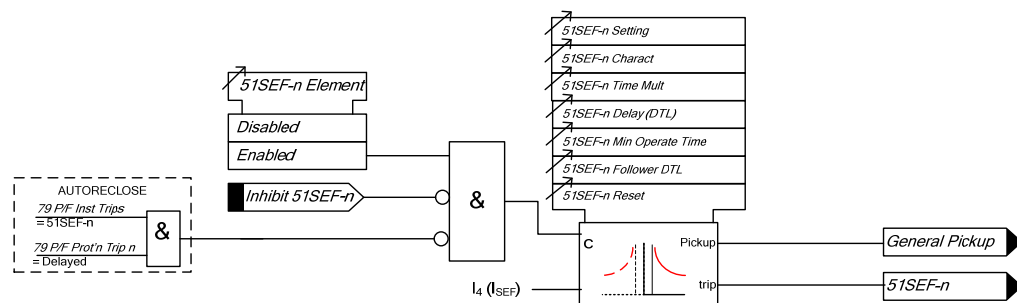

Figure 1-37 Logic Diagram: 7SR11 SEF Time Delayed Element (51SEF)

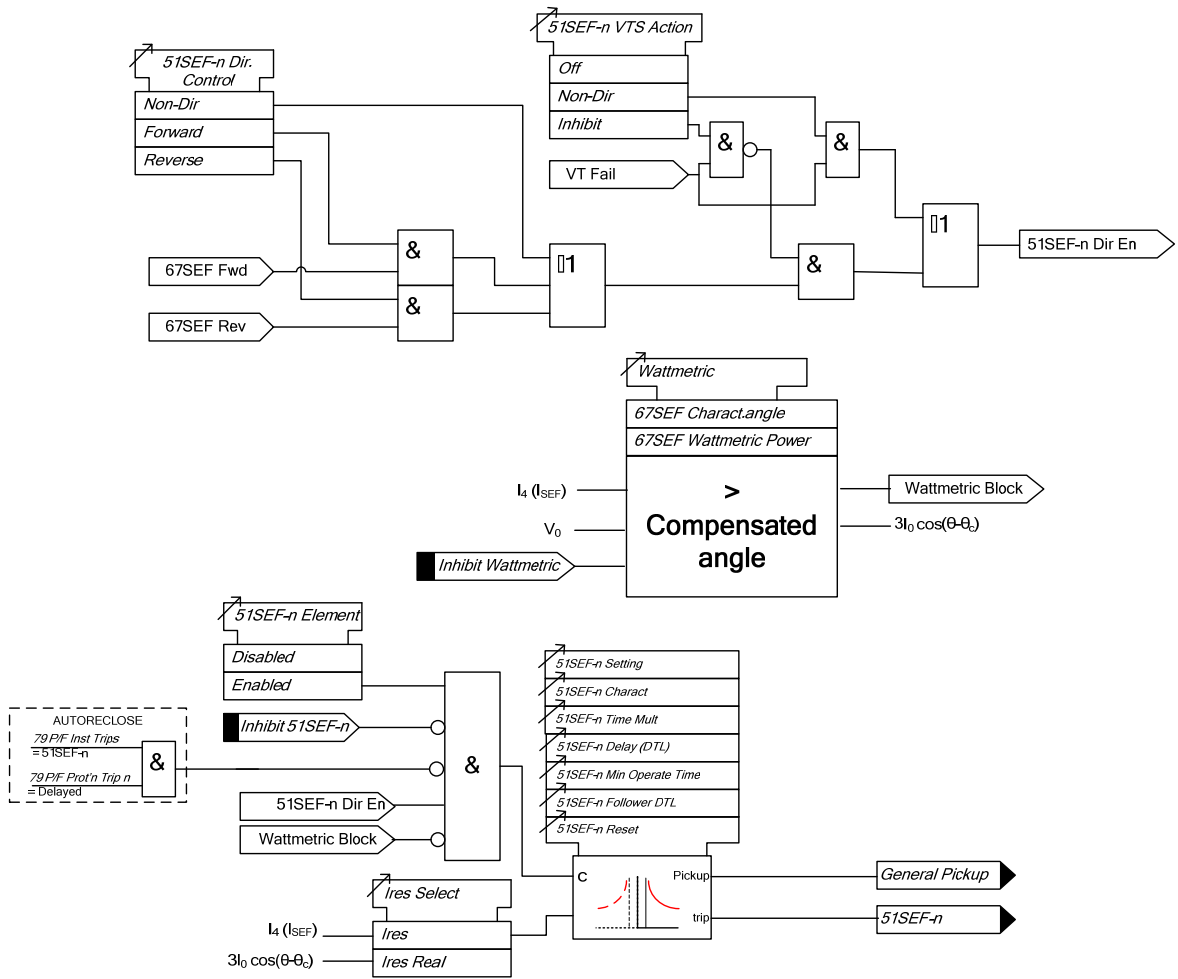

Figure 1-38 Logic Diagram: 7SR12 SEF Time Delayed Element (51SEF)

3.5 Current Protection: High Impedance Restricted Earth Fault - (64H)

One high impedance Restricted Earth Fault (REF) element is provided **64H-1**.

The relay utilises fundamental current measurement values for this function.

The single phase current input is derived from the residual output of line/neutral CTs connected in parallel. An external stabilising resistor must be connected in series with this input to ensure that this element provides a high impedance path.

64H Current Setting sets the pick-up current level. An output is given after elapse of the **64H Delay** setting.

External components – a series stabilising resistor and a non-linear resistor – are used with this function. See 'Applications Guide' for advice in specifying suitable component values.

Operation of the high impedance element can be inhibited from:

Inhibit 64H A binary or virtual input.

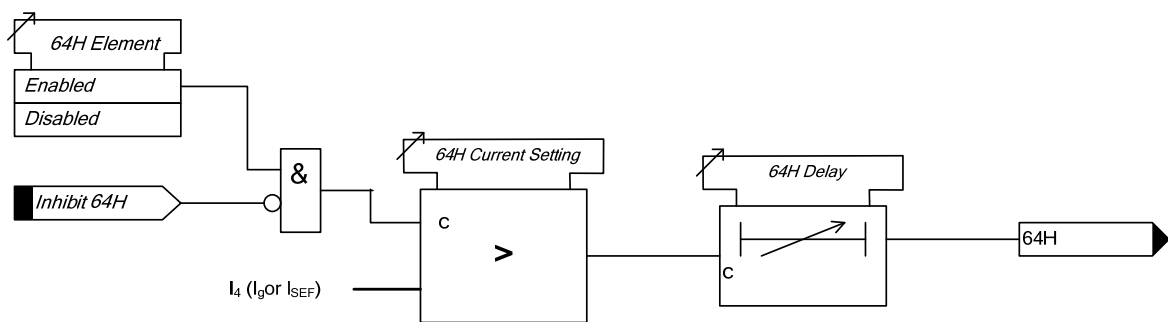

Figure 1-39 Logic Diagram: High Impedance REF (64H)

3.6 Current Protection: Cold Load (51c)

The setting of each shaped overcurrent element (51-n) can be inhibited and alternative 'cold load' settings (51c-n) can be applied for a period following circuit switch in.

The Cold Load settings are applied after the circuit breaker has been open for longer than the **Pick-Up Time** setting.

Following circuit breaker closure the 'cold load' overcurrent settings will revert to those defined in the Phase Overcurrent menu (51-n) after either elapse of the **Drop-Off Time** setting or when the measured current falls below the **Reduced Current Level** setting for a time in excess of **Reduced Current Time** setting.

During cold load settings conditions any directional settings applied in the Phase Overcurrent menu are still applicable.

A CB 'Don't Believe It' (DBI) alarm condition, see Section 4.3, is not acted on, causing the element to remain operating in accordance with the relevant 51-n settings. Where the **Reduced Current** setting is set to **OFF** reversion to 51-n settings will only occur at the end of the **Drop-Off Time**. If any element is picked up on expiry of **Drop-Off Time** the relay will issue a trip (and lockout if a recloser is present).

If the circuit breaker is re-opened before expiry of the **Drop-Off Time** the drop-off timer is held but not reset. Resetting the timer for each trip could result in damaging levels of current flowing for a prolonged period during a rapid sequence of trips/closes.

Cold load trips use the same binary output(s) as the associated 51-n element.

Operation of the cold load element can be inhibited from:

Inhibit Cold Load A binary or virtual input.

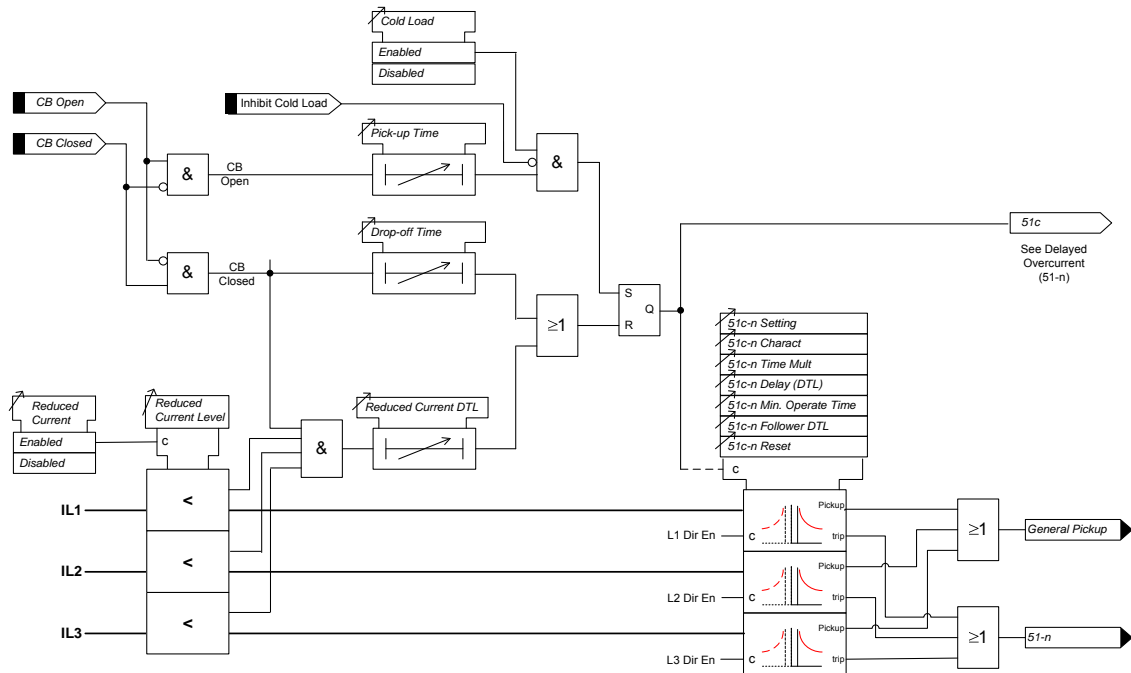

Figure 1-40 Logic Diagram: Cold Load Settings (51c)

3.7 Current Protection: Negative Phase Sequence Overcurrent - (46NPS)

The negative sequence phase (NPS) component of current (I_2) is derived from the three phase currents. It is a measure of the quantity of unbalanced current in the system.

Two NPS current elements are provided – **46IT** and **46DT**.

The **46IT** element can be configured to be either definite time lag (DTL) or inverse definite minimum time (IDMT), **46IT Setting** sets the pick-up current level for the element.

A number of shaped characteristics are provided. An inverse definite minimum time (IDMT) characteristic is selected from IEC and ANSI curves using **46IT Char**. A time multiplier is applied to the characteristic curves using the **46IT Time Mult** setting. Alternatively, a definite time lag delay (DTL) can be chosen using **46ITChar**. When Definite Time Lag (DTL) is selected the time multiplier is not applied and the **46IT Delay (DTL)** setting is used instead.

The **46IT Reset** setting can apply a **definite time delayed** or **ANSI (DECAYING)** reset.

The **46DT** element has a DTL characteristic. **46DT Setting** sets the pick-up current and **46DT Delay** the follower time delay.

Operation of the negative phase sequence overcurrent elements can be inhibited from:

- | | |
|---------------------|----------------------------|
| Inhibit 46IT | A binary or virtual input. |
| Inhibit 46DT | A binary or virtual input. |

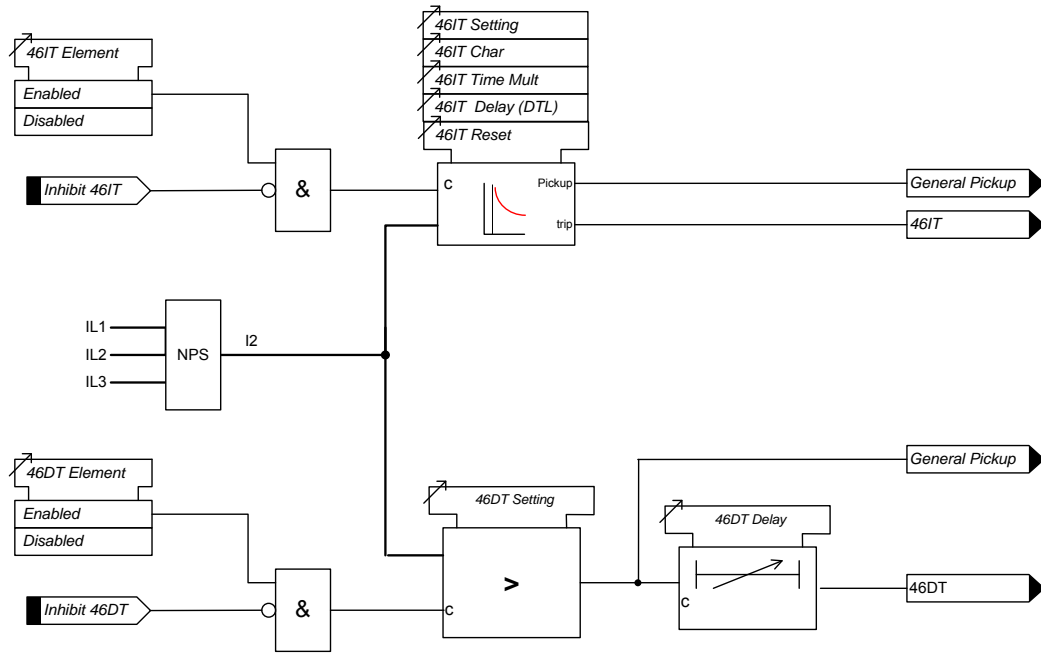

Figure 1-41 Logic Diagram: Negative Phase Sequence Overcurrent (46NPS)

3.8 Current Protection: Under-Current (37)

Two under-current elements are provided **37-1 & 37-2** for phase currents and two for the earth or sensitive earth fault input **37G-1 & 37G-2 or 37SEF-1 & 37SEF-2**

Each phase has an independent level detector and current-timing element. **37-n Setting** sets the pick-up current. An output is given after elapse of the **37-n Delay** setting.

An output is also given to indicate the operated phase.

Operation of the under-current elements can be inhibited from:

- Inhibit 37-n** A binary or virtual input.
- 37U/I Guard Setting** 0.05,0.1..5xIn

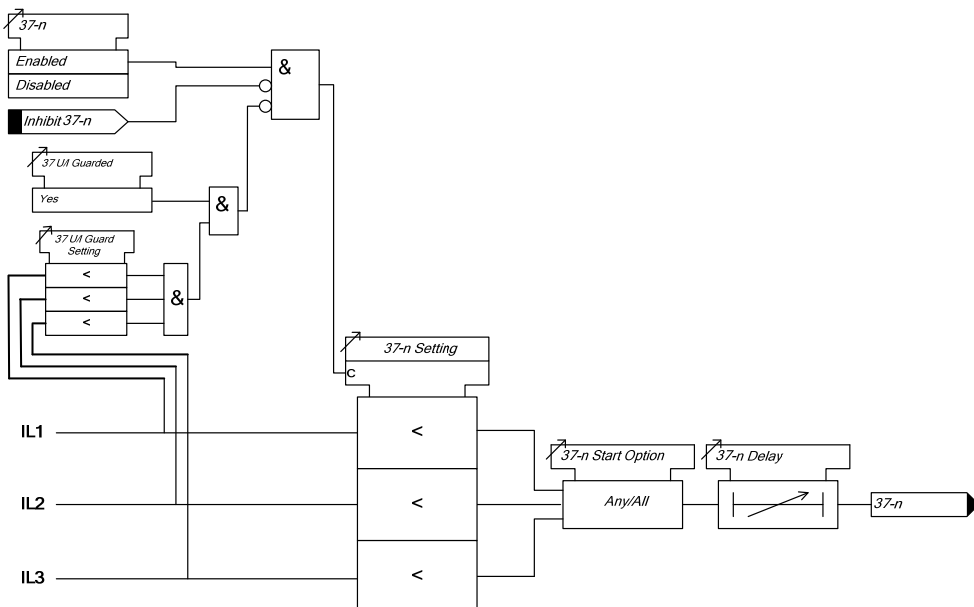

Figure 1-42 Logic Diagram: Phase Current Inputs Undercurrent Detector (37)

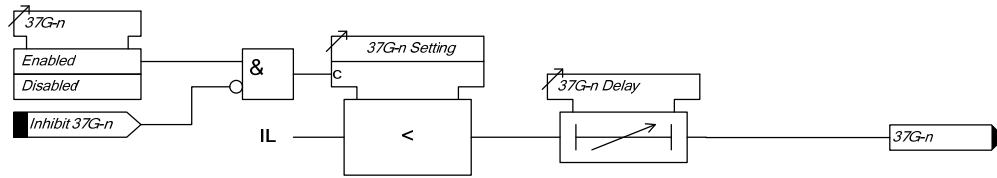

Figure 1-43 Logic Diagram: Earth Current Inputs Undercurrent Detector (37G)

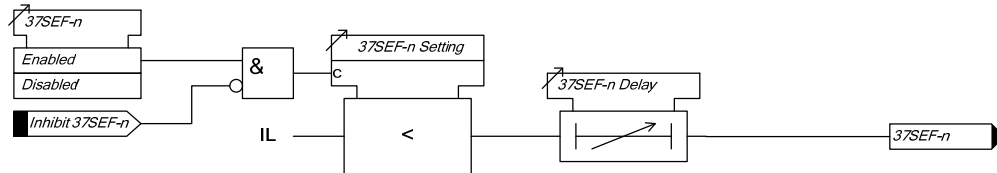

Figure 1-44 Logic Diagram: Sensitive Earth Current Inputs Undercurrent Detector (37SEF)

3.9 Current Protection: Thermal Overload (49)

The relay provides a thermal overload suitable for the protection of static plant. Phase segregated elements are provided. The temperature of the protected equipment is not measured directly. Instead, thermal overload conditions are calculated using the measure True RMS current.

Should the current rise above the **49 Overload Setting** for a defined time an output signal will be initiated. The operating time is a function of thermal time constant **49 Time Constant** and previous current levels.

Operate Time (t):-

$$t = \tau \times \ln \left\{ \frac{I^2 - I_P^2}{I^2 - (k \times I_B)^2} \right\}$$

Where T = Time in minutes

τ = **49 Time Constant** setting (minutes)

ln = Log Natural

I = measured current

IP = Previous steady state current level

k = Constant

IB = Basic current, typically the same as In

k.IB = **49 Overload** Setting (I θ)

Additionally, an alarm can be given if the thermal state of the system exceeds a specified percentage of the protected equipment's thermal capacity **49 Capacity Alarm** setting.

For the heating curve:

$$\theta = \frac{I^2}{I_\theta^2} \cdot (1 - e^{-t/\tau}) \times 100\%$$

Where: θ = thermal state at time t

I = measured thermal current

I θ = **49 Overload** setting (or k.IB)

The final steady state thermal condition can be predicted for any steady state value of input current where $t > \tau$,

$$\theta_F = \frac{I^2}{I_\theta^2} \times 100\%$$

Where: θ_F = final thermal state before disconnection of device

49 Overload Setting I_θ is expressed as a multiple of the relay nominal current and is equivalent to the factor $k_{.1B}$ as defined in the IEC255-8 thermal operating characteristics. It is the value of current above which 100% of thermal capacity will be reached after a period of time and it is therefore normally set slightly above the full load current of the protected device.

The thermal state may be reset from the fascia or externally via a binary input.

Thermal overload protection can be inhibited from:

Inhibit 49 A binary or virtual input.

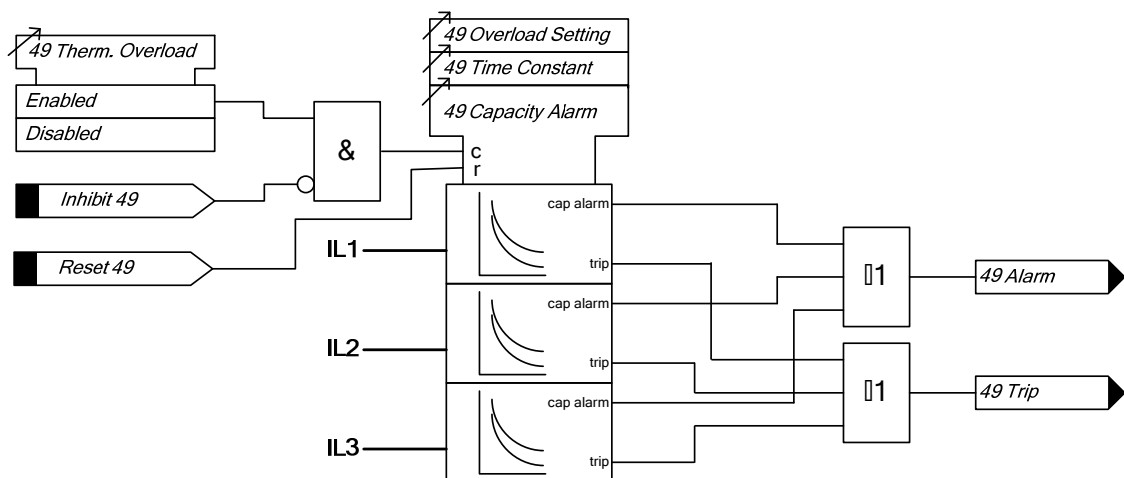

Figure 1-45 Logic Diagram: Thermal Overload Protection (49)

3.10 Current Protection: Line Check 50LC, 50G LC and 50SEF LC – Only software option ‘C’

If a fault appears on the line during the Close Pulse. This prevents a CB being repeatedly closed onto a faulted line. A line check element is provided for phase, earth and sensitive earth fault elements.

In total two line check elements are provided -1, & -2.

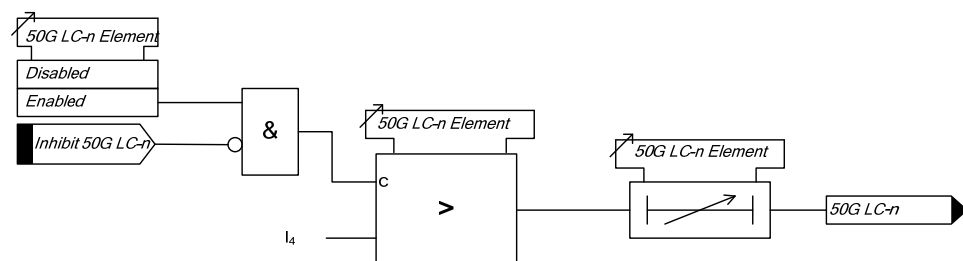

Figure 1-46 Logic Diagram: 50G Line Check Elements (50G LC)

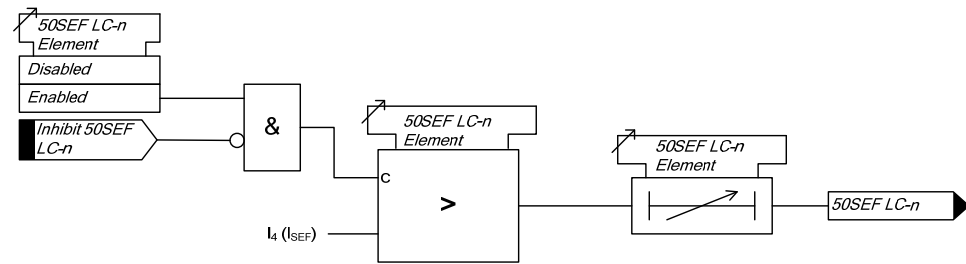

Figure 1-47 Logic Diagram: 50SEF Line Check Elements (50SEF LC)

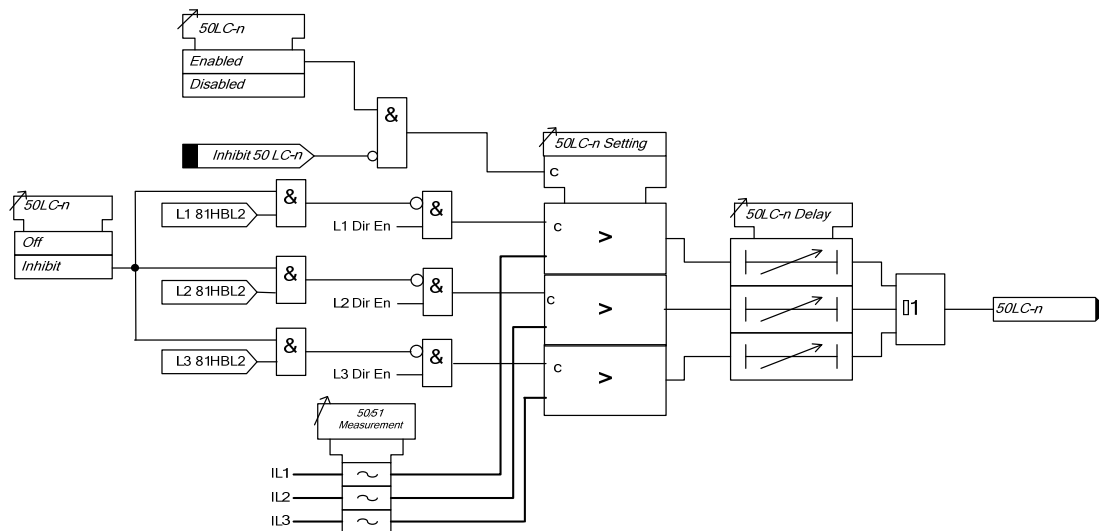

Figure 1-48 Logic Diagram: 50 Line Check Elements (50LC)

3.11 Voltage Protection: Phase Under/Over Voltage (27/59) – 7SR12

In total four under/over voltage elements are provided **27/59-1**, **27/59-2**, **27/59-3** & **27/59-4**.

The relay utilises fundamental frequency RMS voltage for this function. All under/over voltage elements have a common setting to measure phase to phase (**Ph-Ph**) or phase to neutral (**Ph-N**) voltage using the **Voltage Input Mode** setting.

Voltage elements can be blocked if all phase voltages fall below the **27/59 U/V Guard** setting.

27/59-n Setting sets the pick-up voltage level for the element.

The sense of the element (undervoltage or overvoltage) is set by the **27/59-n Operation** setting.

The **27/59-n O/P Phases** setting determines whether the time delay is initiated for operation of any phase or only when all phases have detected the appropriate voltage condition. An output is given after elapse of the **27/59-n Delay** setting.

The **27/59-n Hysteresis** setting allows the user to vary the pick-up/drop-off ratio for the element.

Operation of the under/over voltage elements can be inhibited from:

Inhibit 27/59-n	A binary or virtual input.
27/59-n VTSInhibit: Yes	Operation of the VT Supervision function (7SR1205 & 7SR1206).
27/59-n U/V Guarded	Under voltage guard element.

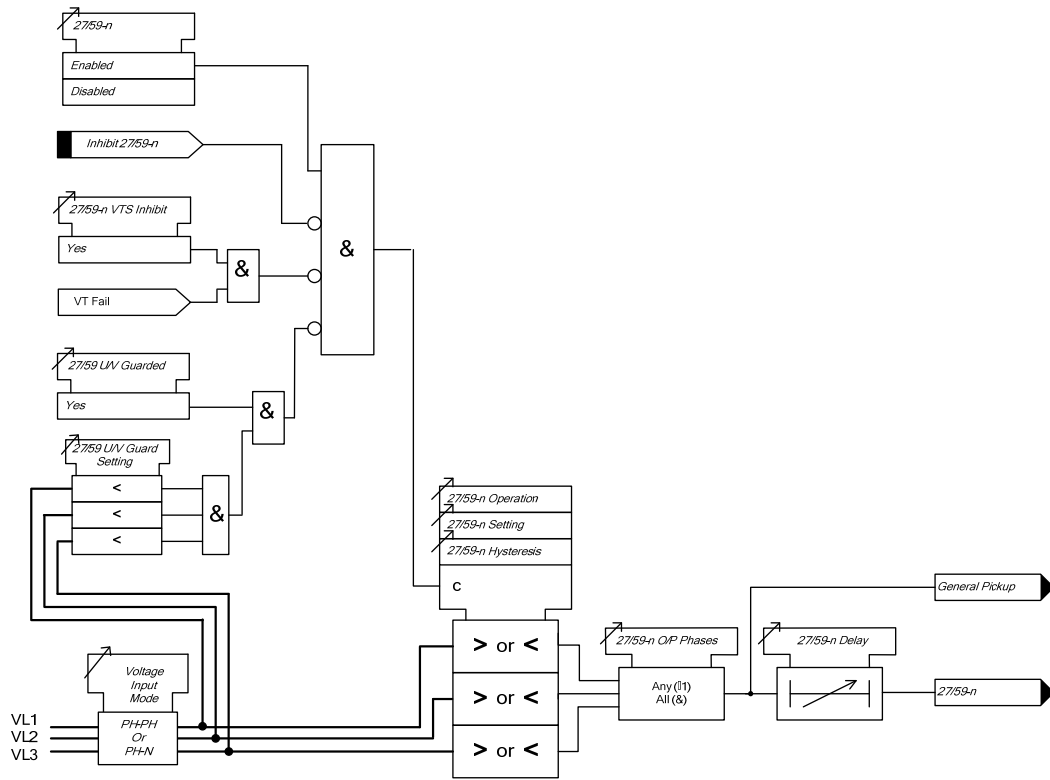

Figure 1-49 Logic Diagram: Under/Over Voltage Elements (27/59)

3.12 Voltage Protection: Negative Phase Sequence Overvoltage (47) – 7SR12

Negative phase sequence (NPS) voltage (V2) is a measure of the quantity of unbalanced voltage in the system. The relay derives the NPS voltage from the three input voltages (VL1, VL2 and VL3).

Two elements are provided **47-1 & 47-2**.

47-n Setting sets the pick-up voltage level for the element.

The **47-n Hysteresis** setting allows the user to vary the pick-up/drop-off ratio for the element.

An output is given after elapse of the **47-n Delay** setting.

Operation of the negative phase sequence voltage elements can be inhibited from:

Inhibit 47-n A binary or virtual input.

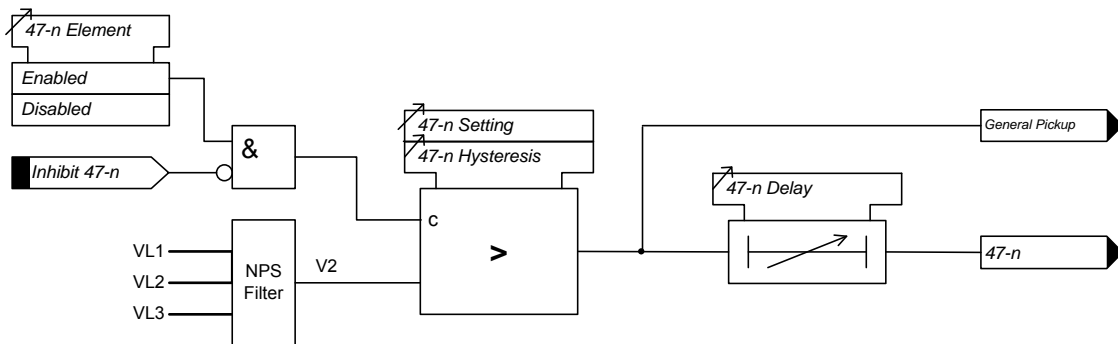

Figure 1-50 Logic Diagram: NPS Overvoltage Protection (47)

3.13 Voltage Protection: Neutral Overvoltage (59N) – 7SR12

Two Neutral Overvoltage (or Neutral Voltage Displacement) elements are provided **59NIT & 59NDT**.

The relay utilises fundamental voltage measurement values for this function. The element can use a direct measurement 3V₀ connection from the voltage transformer or calculate values from a phase to neutral connections from the voltage transformer.

The 59NIT element can be configured to be either definite time lag (DTL) or inverse definite minimum time (IDMT),

59NIT Setting sets the pick-up voltage level (3V₀) for the element.

An inverse definite minimum time (IDMT) can be selected using **59NIT Char**. A time multiplier is applied to the characteristic curves using the **59NIT Time Mult** setting (M):

$$t_{op} = \left[\frac{1000 * M}{\left[\frac{3V_0}{V_s} \right] - 1} \right] \text{ms}$$

Alternatively, a definite time lag delay (DTL) can be chosen using **59NITChar**. When Delay (DTL) is selected the time multiplier is not applied and the **59NIT Delay (DTL)** setting is used instead.

An instantaneous or definite time delayed reset can be applied using the **59NIT Reset** setting.

The 59NDT element has a DTL characteristic. **59NDT Setting** sets the pick-up voltage (3V₀) and **59NDT Delay** the follower time delay.

Operation of the neutral overvoltage elements can be inhibited from:

Inhibit 59NIT A binary or virtual input.

Inhibit59NDT A binary or virtual input.

It should be noted that neutral voltage displacement can only be applied to VT arrangements that allow zero sequence flux to flow in the core i.e. a 5-limb VT or 3 single phase VTs. The VT primary winding neutral must be earthed to allow the flow of zero sequence current.

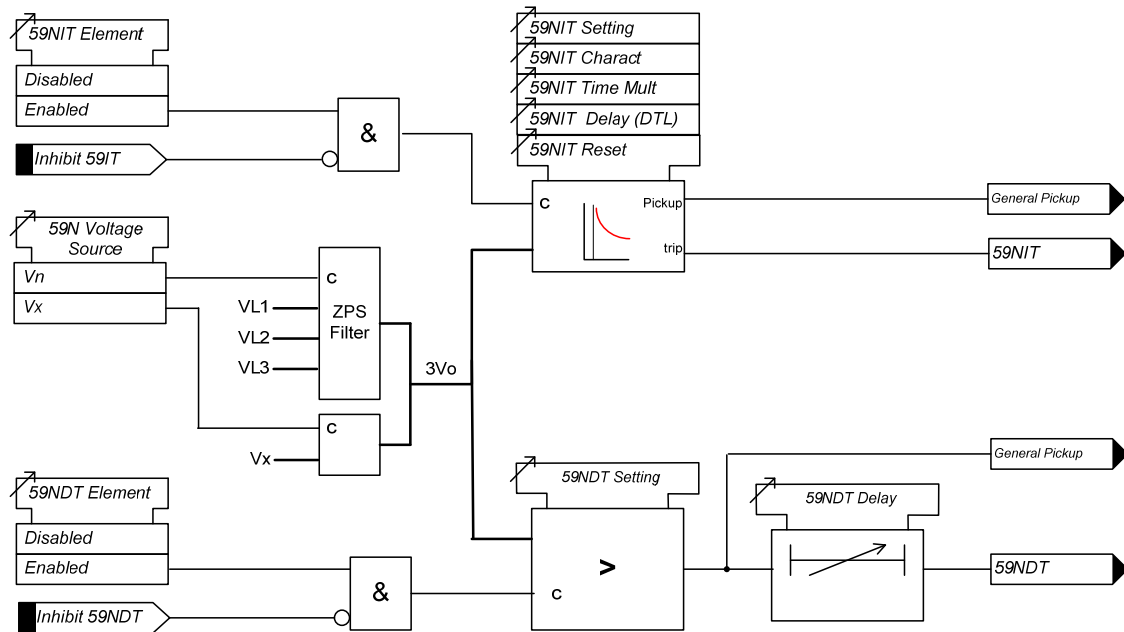

Figure 1-51 Logic Diagram: Neutral Overvoltage Element (59N)

3.14 Voltage Protection: Under/Over Frequency (81) – 7SR12

Four under/over frequency elements are provided in the 7SR12 relay – **81-1, 81-2, 81-3 & 81-4**.

The relay utilises fundamental voltage measurement values for this function. The frequency calculation is based on the highest input voltage derived from the voltage selection algorithm.

Frequency elements are blocked if all phase voltages fall below the **81 U/V Guard** setting.

The sense of the element (under-frequency or over-frequency) is set by the **81-n Operation** setting.

81-n Setting sets the pick-up voltage level for the element.

An output is given after elapse of the **81-n Delay** setting.

The **81-n Hysteresis** setting allows the user to vary the pick-up/drop-off ratio for the element.

Operation of the under/over frequency elements can be inhibited from:

Inhibit 81-n	A binary or virtual input, or function key.
81-n U/V Guarded	Under voltage guard element.

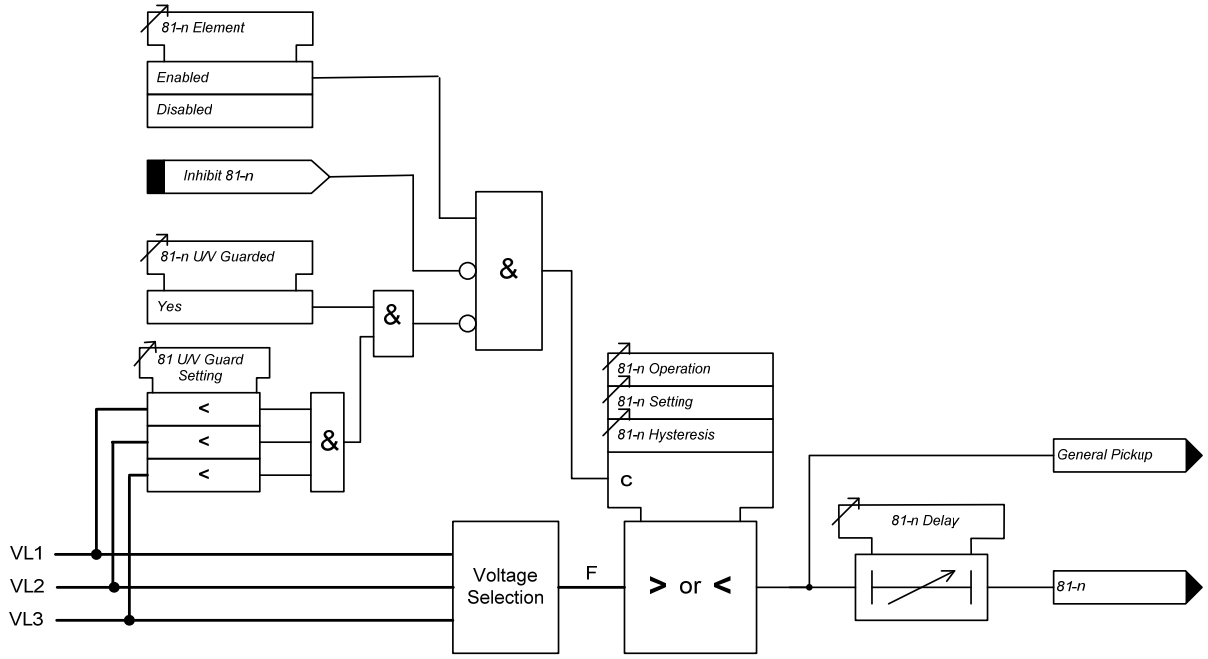

Figure 1-52 Logic Diagram: Under/Over Frequency Detector (81)

Section 4: Control & Logic Functions

4.1 Auto-Reclose (79) Optional Function

4.1.1 Overview

A high proportion of faults on an Overhead Line (OHL) network are transient. These faults can be cleared and the network restored quickly by using Instantaneous (Fast) Protection trips followed by an automated sequence of Circuit Breaker reclosures after the line has been dead for a short time, this 'deadtime' allows the fault current arc to fully extinguish.

Typically this auto reclose (AR) sequence of Instantaneous Trip(s) and Reclose Delays (Dead times) followed by Delayed Trip(s) provide the automatic optimum method of clearing all types of fault i.e. both Transient and Permanent, as quickly as possible and achieving the desired outcome of keeping as much of the Network in-service as possible.

The AR function, therefore, has to:

- Control the type of Protection trip applied at each stage (shot) of a sequence

- Control the Auto Reclose of the Circuit Breaker to provide the necessary network Dead times, to allow time for Arc extinction

- Co-ordinate its Protection and Auto Reclose sequence with other fault clearing devices.

A typical sequence would be – 2 Instantaneous/Highset+1Delayed/HighSet Trips with 1 sec & 10 sec dead times.

The Autoreclose feature may be switched in and out of service by a number of methods, these are:

- Changing Relay Setting **79 Autoreclose ENABLE/DISABLE** (AUTORECLOSE CONFIG menu)

- Enable/Disable in the CONTROL MODE accessed from the fascia

- Via the data communications channel(s),

- From a **79 OUT** binary input. Note the **79 OUT** binary input has priority over the **79 IN** binary input - if both are raised the auto-reclose will be Out of Service.

Knowledge of the CB position status is integral to the auto-reclose functionality. CB auxiliary switches must be connected to **CB Closed** and **CB Open** binary inputs. A circuit breaker's service status is determined by its position i.e. from the binary inputs programmed **CB Open** and **CB Closed**. The circuit breaker is defined as being in service when it is closed. The circuit memory functionality prevents autoreclosing when the line is de-energised, or normally open.

AR is started by a valid protection operation that is internally mapped to trip in the 79 Autoreclose protection menu or an external trip received via a binary input **79 Ext Trip**, while the associated circuit breaker is in service.

The transition from AR started to deadtime initiation takes place when the CB has opened and the protection pickups have reset and the trip relay has reset. If any of these do not occur within the **79 Sequence Fail Timer** setting the relay will Lockout. This prevents the AR being primed indefinitely. **79 Sequence Fail Timer** can be switched to **0** (= OFF).

Once an AR sequence has been initiated, up to 4 reclose operations can be attempted before the AR is locked-out. The relay is programmed to initiate a number of AR attempts, the number is determined by **79 Num Shots**. Each reclosure (shot) is preceded by a time delay - **79 Elem Deadtime n** - giving transient faults time to clear. Separate dead-time settings are provided for each of the 4 recloses and for each of the four fault types – P/F, E/F, SEF and External.

Once a CB has reclosed and remained closed for a specified time period (the Reclaim time), the AR sequence is re-initialised and a Successful Close output issued. A single, common Reclaim time is used (**Reclaim Timer**). When an auto-reclose sequence does not result in a successful reclosure the relay goes to the lockout state.

Indications

The Instruments Menu includes the following meters relevant to the status of the Auto-Reclose and Manual Closing of the circuit breaker: -

Status of the AR sequence , AR Shot Count, CB Open Countdown Timer and CB Close Countdown Timer

Inputs

External inputs to the AR functionality are wired to binary inputs. Functions which can be mapped to these binary inputs include: -

79 In (edge triggered)	79 Block Reclose	79 Line Check
79 Out (level detected)	Block Close CB	79 Reset Lockout
CB Closed	Close CB	79 Lockout
CB Open	Open CB	Hot Line In
79 Ext Trip	79 Trip & Reclose	Hot Line Out
79 Ext Pickup	79 Trip & Lockout	

Outputs

Outputs are fully programmable to either binary outputs or LEDs. Programmable outputs include: -

79 Out Of Service	79 Successful AR	79 Block External
79 In Service	79 Lockout	Successful Manual Close
79 In Progress	79 Close Onto Fault	79 Last Trip Lockout
79 AR Close CB	79 Trip & Reclose	CB fail to close
Manual Close CB	79 Trip & Lockout	

4.1.2 Auto Reclose sequences

The CONTROL & LOGIC>AUTO RECLOSE PROT'N and CONTROL & LOGIC>AUTORECLOSE CONFIG' menus, allow the user to set independent Protection and Auto Reclose sequences for each type of fault i.e. Phase Fault (P/F), Derived/Measured Earth Fault (E/F), Sensitive Earth Fault (SEF) or External Protections (EXTERN). Each Auto Reclose sequence can be user set to up to four-shots i.e. five trips + four reclose sequence, with independently configurable type of Protection Trip. Overcurrent and earth fault elements can be assigned to any combination of Fast (**Inst**), **Delayed** or highset (**HS**) trips. **Deadtime** Delay time settings are independent for each AR shot. The user has programming options for Auto Reclose Sequences up to the maximum shot count i.e.:-

- Inst or Delayed Trip 1 + (DeadTime 1: 0.1s-14400s)**
- + **Inst or Delayed Trip 2 + (DeadTime 2: 0.1s-14400s)**
- + **Inst or Delayed Trip 3 + (DeadTime 3: 0.1s-14400s)**
- + **Inst or Delayed Trip 4 + (DeadTime 4: 0.1s-14400s)**
- + **Inst or Delayed Trip 5 – Lockout.**

The AR function recognizes developing faults and, as the shot count advances, automatically applies the correct type of Protection and associated Dead time for that fault-type at that point in the sequence.

A typical sequence would consist of two **Inst** trips followed by at least one **Delayed** trip. This sequence enables transient faults to be cleared quickly by the **Inst** trip(s) and permanent fault to be cleared by the combined Delayed trip. The delayed trip must be 'graded' with other Recloser/CB's to ensure system discrimination is maintained, ie.. that as much of the system as possible is live after the fault is cleared.

A **HS trips to lockout** setting is provided such that when the number of operations of elements assigned as HS trips reach the setting the relay will go to lockout.

The number of Shots (Closes) is user programmable, note: - only one Shot Counter is used to advance the sequence, the Controller selects the next Protection characteristic/Dead time according to the type of the last Trip in the sequence e.g. PF, EF, SEF or EXTERNAL.

Reclose Dead Time

User programmable dead times are available for each protection trip operation.

The dead time is initiated when the trip output contact reset, the pickup is reset and the CB is open.

The CB close output relay is energised after the dead time has elapsed.

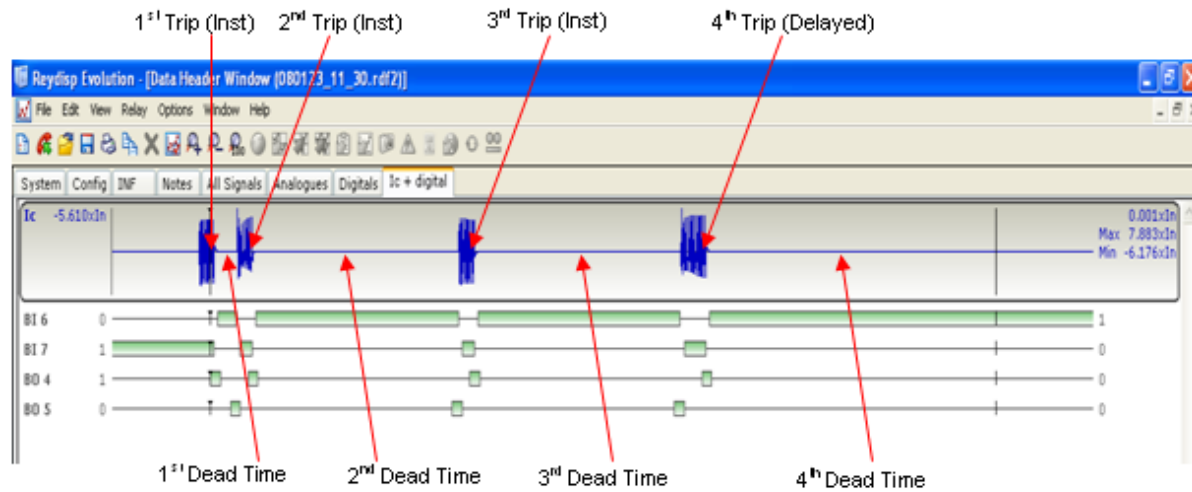

Figure 4-1 Typical AR Sequence with 3 Inst and 1 Delayed trip

4.1.3 Autoreclose Prot'n Menu

This menu presents the Overcurrent Protection elements available for each type of Fault i.e. P/F, E/F (N/G) or SEF and allows the user to select those that are to be applied as **Inst trips**; those that are to be applied as **Delayed Trips**; and those that are to be applied as **HS Trips** (HighSet), as required by the selected sequence. There is no corresponding setting for External as the External protection type is not normally controlled by the Auto Reclose Relay. The resultant configuration enables the Auto Reclose function to correctly apply the required Protection for each shot in a sequence.

4.1.4 Autoreclose Config Menu

This menu allows the following settings to be made:-

79 Autoreclose	Enabled turns ON all AutoReclose Functions.
79 Num Shots	Sets the allowed number of AutoReclose attempts in a sequence.
79 Retry Enable	Enabled configures the relay to perform further attempts to automatically Close the Circuit Breaker where the CB has initially failed to close in response to a Close command. If the first attempt fails the relay will wait for the 79 Retry Interval to expire then attempt to Close the CB again.
79 Retry Attempts	Sets the maximum number of retry attempts.
79 Retry Interval	Sets the time delay between retry attempts.
79 Reclose Blocked Delay	If the CB is not ready to receive a Close command or if system conditions are such that the CB should not be closed immediately e.g. a close-spring is not charged, then a Binary input mapped to Reclose Block can be raised and the Close pulse will not be issued but will be held-back. The 79 Reclose Blocked Delay sets the time Reclose Block is allowed to be raised, if this time delay expires the Relay will go to Lockout. If Reclose Block is cleared, before this time expires, then the CB Close pulse will be issued at that point in time. Dead Time + Reclose Blocked Delay = Lockout.
79 Sequence Fail Timer	Sets the time that AutoReclose start can be primed. Where this time expires before all the DAR start signals are not received i.e. the CB has opened, protection pickups have reset and the trip relay has reset, the Relay goes to Lockout.

79 Sequence Co-Ord When set to **Enabled** the Relay will co-ordinate its sequence and shot count such that it automatically keeps in step with downstream devices as they advance through their sequence. The Relay detects that a pickup has operated but has dropped-off before its associated time delay has expired, it then increments its Shot count and advances to the next stage of the auto-reclose sequence without issuing a trip, this is repeated as long as the fault is being cleared by the downstream device such that the Relay moves through the sequence bypassing the INST Trips and moving on to the Delayed Trip to maintain Grading margins.

Notes on the 'Lockout' State

The Lockout state can be reached for a number of reasons. Lockout will occur for the following: -

- At the end of the **79 Sequence Fail Timer**.
- At the end of the **Reclaim timer** if the CB is in the open position.
- A protection operates during the final Reclaim time.
- If a Close Pulse is given and the CB fails to close.
- The **79 Lockout** binary input is active.
- At the end of the **79 Reclose Blocked Delay** due to presence of a persistent Block signal.
- When the **79 Elem HS Trips to Lockout** count is reached.
- When the **79 Elem Delayed Trips to Lockout** count is reached.

An alarm output is provided to indicate **last trip to lockout**.

Once lockout has occurred, an alarm (**79 Lockout**) is issued and all further Close commands, except manual close, are inhibited.

If the Lockout command is received while a Manual Close operation is in progress, the feature is immediately locked-out.

Once the Lockout condition has been reached, it will be maintained until reset. The following will reset lockout: -

- By a Manual Close command, from fascia, comms or **Close CB** binary input.
- By a **79 Reset Lockout** binary input, provided there is no signal present that will cause Lockout.
- At the end of the **79 Minimum LO Delay** time setting if **79 Reset LO by Timer** is selected to **ENABLED**, provided there is no signal present which will cause Lockout.
- Where Lockout was entered by an A/R Out signal during an Autoreclose sequence then a **79 In** signal must be received before Lockout can reset.
- By the **CB Closed** binary input, provided there is no signal present which will cause Lockout.

The Lockout condition has a delayed drop-off of 2s. The Lockout condition can not be reset if there is an active lockout input.

4.1.5 P/F Shots sub-menu

This menu allows the Phase fault trip/reclose sequence to be parameterized:-

- | | |
|--|---|
| 79 P/F Prot'n Trip1 | The first protection Trip in the P/F sequence can be set to either Inst or Delayed . |
| 79 P/F Deadtime 1 | Sets the first Reclose Delay (Dead time) in the P/F sequence. |
| 79 P/F Prot'n Trip2 | The second protection Trip in the P/F sequence can be set to either Inst or Delayed . |
| 79 P/F Deadtime 2 | Sets the second Reclose Delay (Dead time) in the P/F sequence. |
| 79 P/F Prot'n Trip3 | The third protection Trip in the P/F sequence can be set to either Inst or Delayed . |
| 79 P/F Deadtime 3 | Sets the third Reclose Delay (Dead time) in the P/F sequence. |
| 79 P/F Prot'n Trip 4 | The fourth protection Trip in the P/F sequence can be set to either Inst or Delayed . |
| 79 P/F Deadtime 4 | Sets the fourth Reclose Delay (Dead time) in the P/F sequence. |
| 79 P/F Prot'n Trip5 | The fifth and last protection Trip in the P/F sequence can be set to either Inst or Delayed . |
| 79 P/F HighSet Trips to Lockout | Sets the number of allowed HighSet trips. The relay will go to Lockout on the last HighSet Trip. This function can be used to limit the duration and number of high current trips that the Circuit Breaker is required to perform, if the fault is permanent and close to the Circuit Breaker then there is no point in forcing a number of Delayed Trips before the Relay goes to Lockout – that sequence will be truncated. |
| 79 P/F Delayed Trips to Lockout | Sets the number of allowed Delayed trips, Relay will go to Lockout on the last Delayed Trip. This function limits the number of Delayed trips that the Relay can perform when the Instantaneous protection Elements are externally inhibited for system operating reasons - sequences are truncated. |

4.1.6 E/F Shots sub-menu

This menu allows the Earth Fault trip/reclose sequence to be parameterized:-

As above but E/F settings.

4.1.7 SEF Shots sub-menu

This menu allows the Sensitive Earth trip/reclose sequence to be parameterized:-

As above but SEF Settings, Note: - SEF does not have HighSets

4.1.8 Extern Shots sub-menu

This menu allows the External Protection auto-reclose sequence to be parameterized:-

- | | |
|----------------------------|--|
| 79 P/F Prot'n Trip1 | Not Blocked/Blocked - Blocked raises an output which can be mapped to a Binary output to Block an External Protection's Trip Output. |
| 79 P/F Deadtime 1 | Sets the first Reclose Delay (Deadtime) for the External sequence. |
| 79 P/F Prot'n Trip2 | Not Blocked/Blocked - Blocked raises an output which can be mapped to a Binary Output to Block an External Protection's second Trip output. |
| 79 P/F Deadtime 2 | Sets the second Reclose Delay (Deadtime) in the External sequence. |
| 79 P/F Prot'n Trip3 | Not Blocked/Blocked - Blocked raises an output which can be mapped to a Binary output to Block an External Protection's third Trip Output. |
| 79 P/F Deadtime 3 | Sets the third Reclose Delay (Deadtime) in the External sequence. |
| 79 P/F Prot'n Trip4 | Not Blocked/Blocked - Blocked raises an output which can be mapped to a Binary output to Block an External Protection's fourth Trip Output. |
| 79 P/F Deadtime 4 | Sets the fourth Reclose Delay (Deadtime) in the External sequence. |
| 79 P/F Prot'n Trip5 | Not Blocked/Blocked - Blocked raises an output which can be mapped to a Binary output to Block an External Protection's fifth Trip Output. |

79 P/F Extern Trips to Lockout - Sets the number of allowed External protection' trips, Relay will go to Lockout on the last Trip.

These settings allow the user to set-up a separate AutoReclose sequence for external protection(s) having a different sequence to P/F, E/F or SEF protections. The '**Blocked**' setting allows the Autoreclose sequence to raise an output at any point in the sequence to Block further Trips by the External Protection thus allowing the Overcurrent P/F or Earth Fault or SEF elements to apply Overcurrent Grading to clear the fault.

Other Protection Elements in the Relay can also be the cause of trips and it may be that AutoReclose is required; the External AutoReclose sequence can be applied for this purpose. By setting-up internal Quick Logic equation(s) the user can define and set what should occur when any one of these other elements operates.

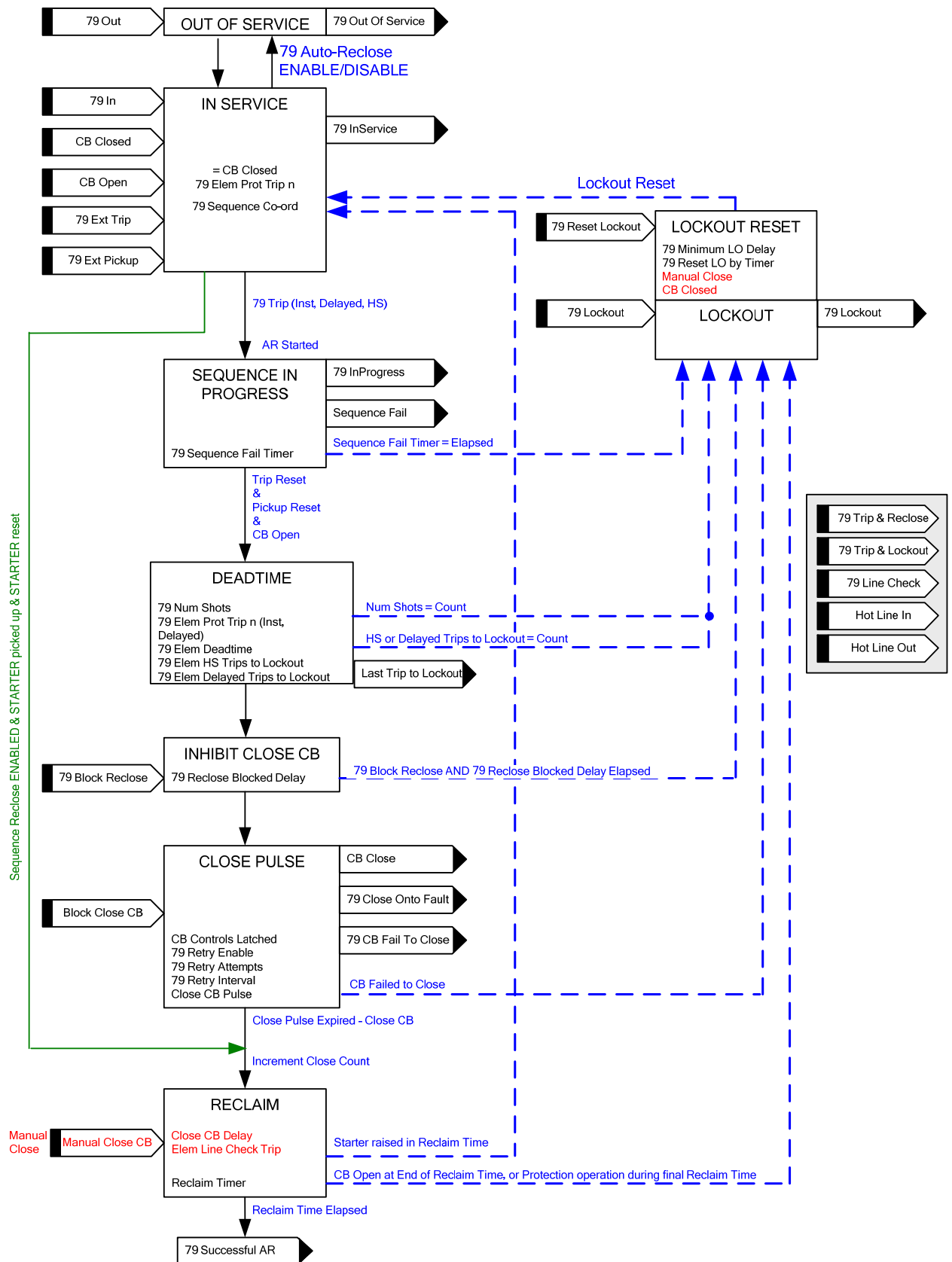

Figure 4-2 Basic Auto-Reclose Sequence Diagram

4.2 Manual CB Control

A Manual Close Command can be initiated in one of three ways: via a **Close CB** binary input, via the data communication Channel(s) or from the relay CONTROL MODE menu. It causes an instantaneous operation via **79MC Close CB** binary output, over-riding any DAR sequence in progress.

Repeated Manual Closes are avoided by checking for Positive edge triggers. Even if the Manual Close input is constantly energised the relay will only attempt one close.

A Manual Close will initiate **Line Check** if enabled. If a fault appears on the line during the Close Pulse or during the Reclaim Time with Line Check enabled, the relay will initiate a Trip and Lockout. This prevents a CB being repeatedly closed onto a faulted line. Where **Line Check = DELAYED** then instantaneous protection is inhibited until the reclaim time has elapsed.

Manual Close resets Lockout, if the conditions that set Lockout have reset i.e. there is no trip or Lockout input present.

Manual Close cannot proceed if there is a Lockout input present.

With the Autoreclose function set to Disabled the Manual Close control is still active.

CB Controls Latched

CB controls for manually closing and tripping can be latched for extra security.

With Reset operation, the control resets when the binary input drops off. This can lead to multiple control restarts due to bounce on the binary input signal.

With Latch operation, the close or trip sequence always continues to completion (or sequence failure) and bounce on the binary input is ignored.

Reset operation can be useful, however, as it allows a close or trip sequence to be aborted by dropping off the binary input signal.

Close CB Delay

The Close CB Delay is applicable to manual CB close commands received through a **Close CB** binary input or via the Control Menu. Operation of the **79 MC Close CB** binary output is delayed by the **Close CB Delay** setting. The status of this delay is displayed on the relay fascia as it decrements towards zero. Only when the delay reaches zero will the close command be issued and related functionality initiated.

Blocked Close Delay

The close command may be delayed by a **Block Close CB** signal applied to a binary input. This causes the feature to pause before it issues the CB close command and can be used, for example, to delay CB closure until the CB energy has reached an acceptable level. If the Block signal has not been removed before the end of the defined time, **Blocked Close Delay**, the relay will go to the lockout state.

Open CB Delay

The Open CB Delay setting is applicable to CB trip commands received through an **Open CB** binary input or via the Control Menu. Operation of the **Open CB** binary output is delayed by the **Open CB Delay** setting. The status of this delay is displayed on the relay fascia as it decrements towards zero. Only when the delay reaches zero will the trip command be issued and related functionality initiated.

It should be noted that a CB trip initiated by an **Open CB** command is fundamentally different from a CB trip initiated by a protection function. A CB trip caused by a **CB Open** command will not initiate functionality such as circuit-breaker fail, fault data storage, I²t measurement and operation counter.

4.3 Circuit Breaker (CB)

This menu includes relay settings applicable to both manual close (MC) and auto-reclose (AR) functionality.

Close CB Pulse

The duration of the **CB Close Pulse** is settable to allow a range of CBs to be used. The Close pulse will be terminated if any protection pick-up operates or a trip occurs. This is to prevent Close and Trip Command pulses existing simultaneously. A **79 Close On Fault** Output is given if a pick-up or trip operates during the Close Pulse. This can be independently wired to Lockout.

'CB Failed To Open' and 'CB Failed to Close' features are used to confirm that a CB has not responded correctly to each Trip and Close Command. If a CB fails to operate, the DAR feature will go to lockout.

'CB Close Fail' is issued if the CB is not closed at the end of the close pulse, **CB Close Pulse**.

Reclaim Timer

The 'Reclaim time' will start each time a Close Pulse has timed out and the CB has closed.

Where a protection pickup is raised during the reclaim time the relay advances to the next part of the reclose sequence.

The relay goes to the Lockout state if the CB is open at the end of the reclaim time or a protection operates during the final reclaim time.

Open CB Pulse

The duration of the CB open pulse is user settable to allow a range of CBs to be used.

The CB open pulse must be long enough for the CB to physically open.

CB Travel Alarm

The CB Open/CB Closed binary inputs are continually monitored to track the CB Status.

The CB should only ever be in 3 states:

CB Status	CB Open binary input	CB Closed binary input
CB is Open	1	0
CB is Closed	0	1
CB is Travelling between the above 2 states	0	0

The Relay goes to Lockout and the CB Alarm output is given where the Travelling condition exists for longer than the **CB Travel Alarm** setting.

An instantaneous CB Alarm is given for a 1/1 state – i.e. where the CB indicates it is both Open and Closed at the same time.

Hot Line In/Out

When 'Hot Line' is enabled all auto reclose sequences are inhibited and any fault causes an instantaneous trip to lockout.

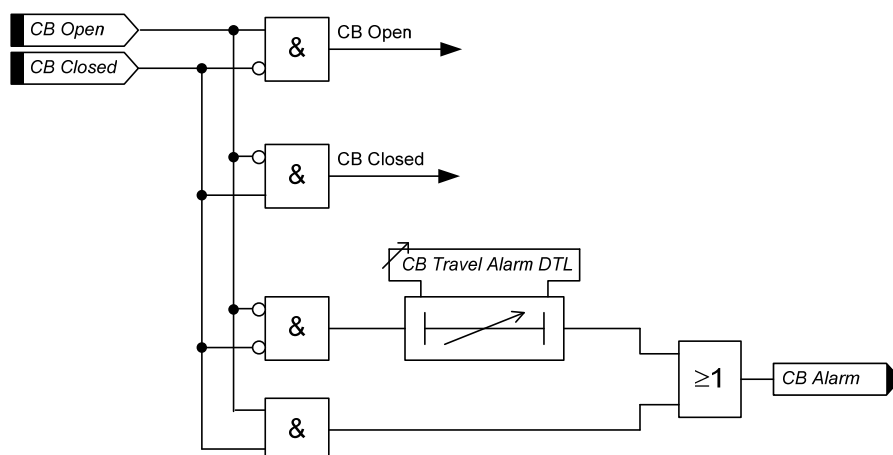

Figure 4-3 Logic Diagram: Circuit Breaker Status

79 Minimum LO Delay (Only in Auto-reclose models)

Sets the time that the Relay's Lockout condition is maintained. After the last allowed Trip operation in a specific sequence the Circuit Breaker will be left locked-out in the open position and can only be closed by manual or remote SCADA operation. The **79 Minimum Lockout Delay** timer can be set to delay a too-fast manual close after lockout, this prevents an operator from manually closing onto the same fault too quickly and thus performing multiple sequences and possibly burning-out Plant.

79 Reset LO by Timer(Only in Auto-reclose models)

Set to **Enabled** this ensures that the Lockout condition is reset when the timer expires, Lockout indication will be cleared; otherwise, set to Disabled, the Lockout condition will be maintained until the CB is Closed by a Close command.

CB Control Trip Time

When this is set to **Enabled**, the relay will measure the trip time following operation of a CB control open output or a CB Trip output. The trip time is delayed by the CB trip meter.

When this is set to **Disabled**, the relay will measure the trip time following operation of a CB Trip output only. Operation of a CB control open output will then not cause the trip time to be measured.

Trip Time Alarm

The CB Trip Time meter displays the measured time between the trip being issued and the CB auxiliary contacts changing state. If this measured time exceeds the **Trip Time Alarm** time, a Trip Time Alarm output is issued.

Trip Time Adjust

This allows for the internal delays caused by the relay – especially the delay before a binary input operates – to be subtracted from the measured CB trip time. This gives a more accurate measurement of the time it took for the CB to actually trip.

4.4 Quick Logic

The 'Quick Logic' feature allows the user to input up to 4 logic equations (E1 to E4) in text format. Equations can be entered using Reydisp or at the relay fascia.

Each logic equation is built up from text representing control characters. Each can be up to 20 characters long. Allowable characters are:

0, 1, 2, 3, 4, 5, 6, 7, 8, 9	Digit
()	Parenthesis
!	'NOT' Function
.	'AND' Function
^	'EXCLUSIVE OR' Function
+	'OR' Function
En	Equation (number)
In	Binary Input (number)
	'1' = Input energised, '0' = Input de-energised
Ln	LED (number)
	'1' = LED energised, '0' = LED de-energised
On	Binary output (number)
	'1' = Output energised, '0' = Output de-energised
Vn	Virtual Input/Output (number)
	'1' = Virtual I/O energised, '0' = Virtual I/O de-energised

Example Showing Use of Nomenclature

$$E1 = ((I1 \wedge V1) \cdot !O2) + L1$$

Equation 1 = ((Binary Input 1 XOR Virtual I/O 1) AND NOT Binary Output 2) OR LED 1

When the equation is satisfied (=1) it is routed through a pick-up timer (**En Pickup Delay**), a drop-off timer (**En Dropoff Delay**), and a counter which instantaneously picks up and increments towards its target (**En Counter Target**).

The counter will either maintain its count value **En Counter Reset Mode = OFF**, or reset after a time delay:

En Counter Reset Mode = Single Shot: The **En Counter Reset Time** is started only when the counter is first incremented (i.e. counter value = 1) and not for subsequent counter operations. Where **En Counter Reset Time** elapses and the count value has not reached its target the count value is reset to zero.

En Counter Reset Mode = Multi Shot: The **En Counter Reset Time** is started each time the counter is incremented. Where **En Counter Reset Time** elapses without further count increments the count value is reset to zero.

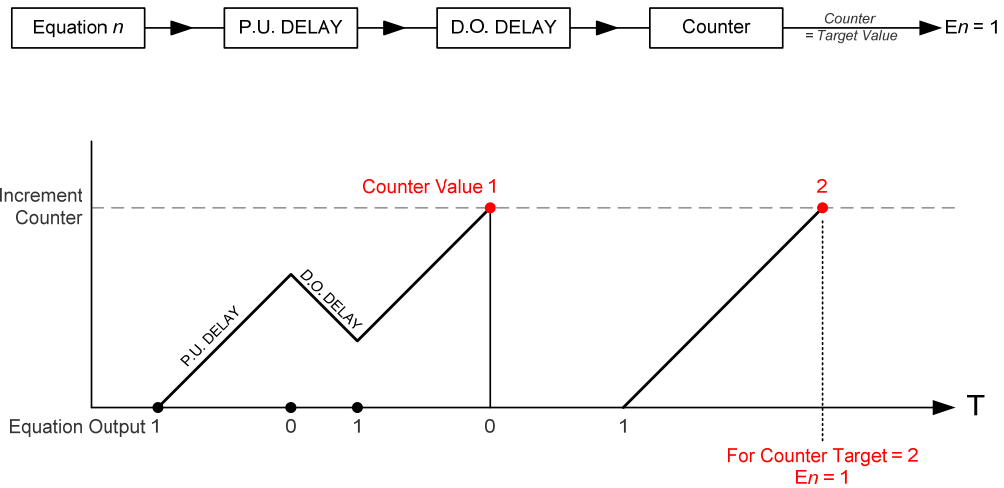

Figure 4-4 Sequence Diagram: Quick Logic PU/DO Timers (Counter Reset Mode Off)

When the count value = **En Counter Target** the output of the counter (En) = 1 and this value is held until the initiating conditions are removed when En is instantaneously reset.

The output of En is assigned in the OUTPUT CONFIG>OUTPUT MATRIX menu where it can be programmed to any binary output (O), LED (L) or Virtual Input/Output (V) combination.

Protection functions can be used in Quick Logic by mapping them to a Virtual Input / Output.

Refer to Chapter 7 – Applications Guide for examples of Logic schemes.

Section 5: Supervision Functions

5.1 Circuit Breaker Failure (50BF)

The circuit breaker fail function has two time delayed outputs that can be used for combinations of re-tripping or back-tripping. CB Fail outputs are given after elapse of the **50BF-1 Delay** or **50BF-2 Delay** settings. The two timers run concurrently.

The circuit breaker fail protection time delays are initiated either from:

An output **Trip Contact** of the relay (MENU: OUTPUT CONFIG\TRIP CONFIG\Trip Contacts), or

A binary or virtual input assigned to **50BF Ext Trig** (MENU: INPUT CONFIG\INPUT MATRIX\50BF Ext Trig).

A binary or virtual input assigned to **50BF Mech Trip** (MENU: INPUT CONFIG\INPUT MATRIX\ 50BF Mech Trip).

CB Fail outputs will be issued providing any of the 3 phase currents are above the **50BF Setting** or the current in the fourth CT is above **50BF-I4** for longer than the **50BF-n Delay** setting, or for a mechanical protection trip the circuit breaker is still closed when the **50BF-n Delay** setting has expired – indicating that the fault has not been cleared.

Both **50BF-1** and **50BF-2** can be mapped to any output contact or LED.

An output is also given to indicate the faulted phase, **50BF PhA**, **50BF PhB**, **50BF PhC** and **50BF EF**

If the **CB Faulty** input (MENU: INPUT CONFIG\INPUT MATRIX\CB Faulty) is energised when a CB trip is given the time delays **50BF-n Delay** will be by-passed and the output given immediately.

Operation of the CB Fail elements can be inhibited from:

Inhibit 50BF

A binary or virtual input.

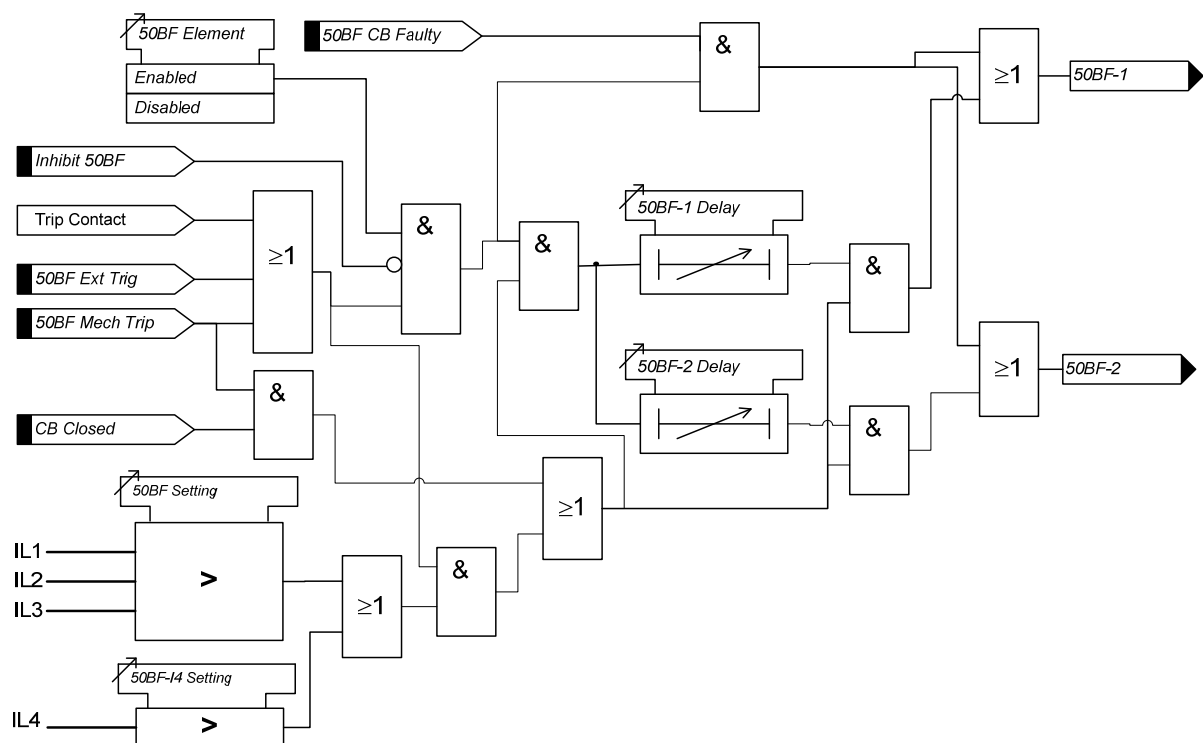

Figure 4-5 Logic Diagram: Circuit Breaker Fail Protection (50BF)

5.2 VT Supervision (60VTS) – 7SR1205 & 7SR1206

1 or 2 Phase Failure Detection

Normally the presence of negative phase sequence (NPS) or zero phase sequence (ZPS) voltage in a power system is accompanied by NPS or ZPS current. The presence of either of these sequence voltages without the equivalent level of the appropriate sequence current is used to indicate a failure of one or two VT phases.

The **60VTS Component** setting selects the method used for the detection of loss of 1 or 2 VT phases i.e. **ZPS** or **NPS** components. The sequence component voltage is derived from the line voltages; suitable VT connections must be available. The relay utilises fundamental voltage measurement values for this function.

The element has user settings **60VTS V** and **60VTS I**. A VT is considered to have failed where the voltage exceeds **60VTS V** while the current is below **60VTS I** for a time greater than **60VTS Delay**.

3 Phase Failure Detection

Under normal load conditions rated PPS voltage would be expected along with a PPS load current within the circuit rating. Where PPS load current is detected without corresponding PPS voltage this could indicate a three phase VT failure. To ensure these conditions are not caused by a 3 phase fault the PPS current must also be below the fault level.

The element has a **60VTS VPPS** setting, an **60VTS IPPS Load** setting and a setting for **60VTS IPPS Fault**. A VT is considered to have failed where positive sequence voltage is below **60VTS VPPS** while positive sequence current is above **IPPS Load** and below **IPPS Fault** level for more than **60VTS Delay**.

External MCB

A binary input can be set as **Ext_Trig 60VTS** to allow the **60VTS Delay** element to be started from an external MCB operating.

Once a VT failure condition has occurred the output is latched on and is reset by any of the following:-

Voltage is restored to a healthy state i.e. above **VPPS** setting while NPS voltage is below **VNPS** setting.

Ext Reset 60VTS A binary or virtual input, or function key and a VT failure condition no longer exists.

Inhibit 60VTS A binary or virtual input.

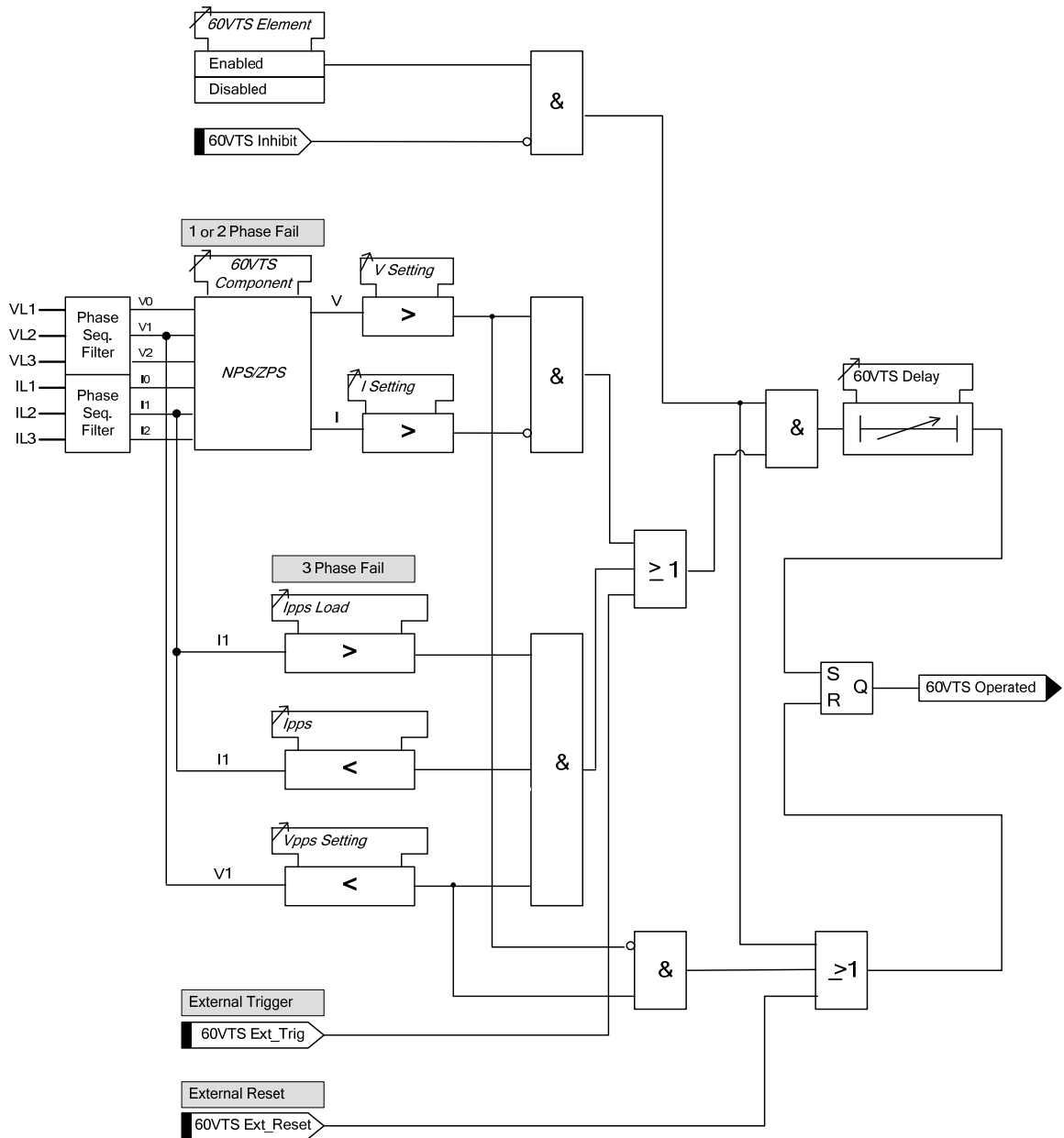

Figure 4-6 Logic Diagram: VT Supervision Function (60VTS)

5.3 CT Supervision (60CTS)

The relay has two methods of detecting a CT failure, depending on the relay model. CT Supervision is only available in relays with four current inputs.

5.3.1 60CTS for 7SR11 (60CTS-I for 7SR12)

The current from each of the Phase Current Transformers is monitored. If one or two of the three input currents falls below the CT supervision current setting **60CTS I** for more than **60CTS Delay** then a CT failure output (**60CTS Operated**) is given. If all three input currents fall below the setting, CT failure is not raised.

An output is also given to indicate the faulted phase, **60CTS-I PhA**, **60CTS-I PhB**, and **60CTS-I PhC**

Operation of the CT supervision elements can be inhibited from:

Inhibit 60CTS A binary or virtual input.

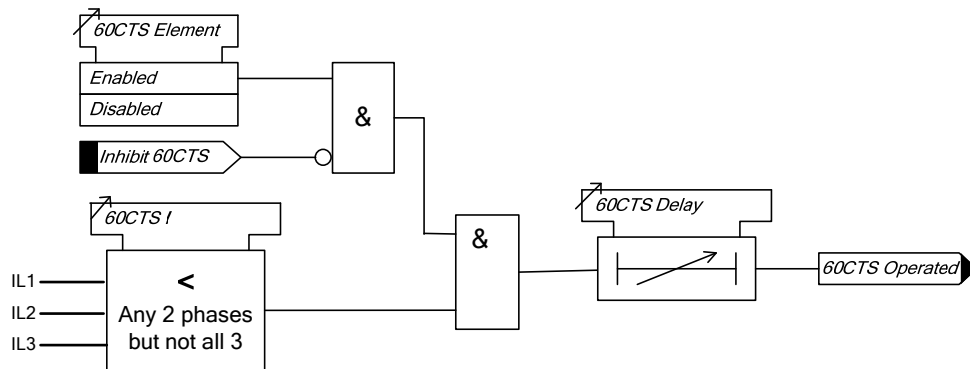

Figure 4-7 Logic Diagram: CT Supervision Function (60CTS) – 7SR11

This function is retained in the 7SR12 as it provides phase discrimination, whereas the standard function provided in the 7SR12 does not.

5.3.2 60CTS for 7SR12

Normally the presence of negative phase sequence (NPS) current in a power system is accompanied by NPS voltage. The presence of NPS current without NPS voltage is used to indicate a current transformer failure.

The element has a setting for NPS current level **60CTS Inps** and a setting for NPS voltage level **60CTS Vnps**. If the negative sequence current exceeds its setting while the negative sequence voltage is below its setting for more than **60CTS Delay** then a CT failure output (**60CTS Operated**) is given.

Operation of the CT supervision elements can be inhibited from:

Inhibit 60CTS A binary or virtual input.

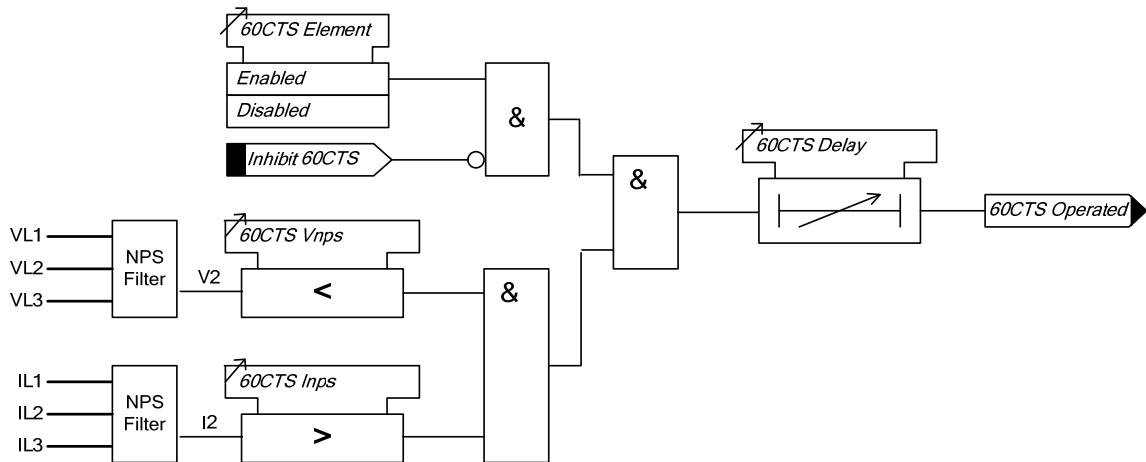

Figure 4-8 Logic Diagram: CT Supervision Function (60CTS) – 7SR12

5.4 Broken Conductor (46BC)

The element calculates the ratio of NPS to PPS currents. Where the NPS:PPS current ratio is above **46BC Setting** an output is given after the **46BC Delay**.

The Broken Conductor function can be inhibited from

Inhibit 46BC	A binary or virtual input.
46BC U/I Guard	A minimum load current

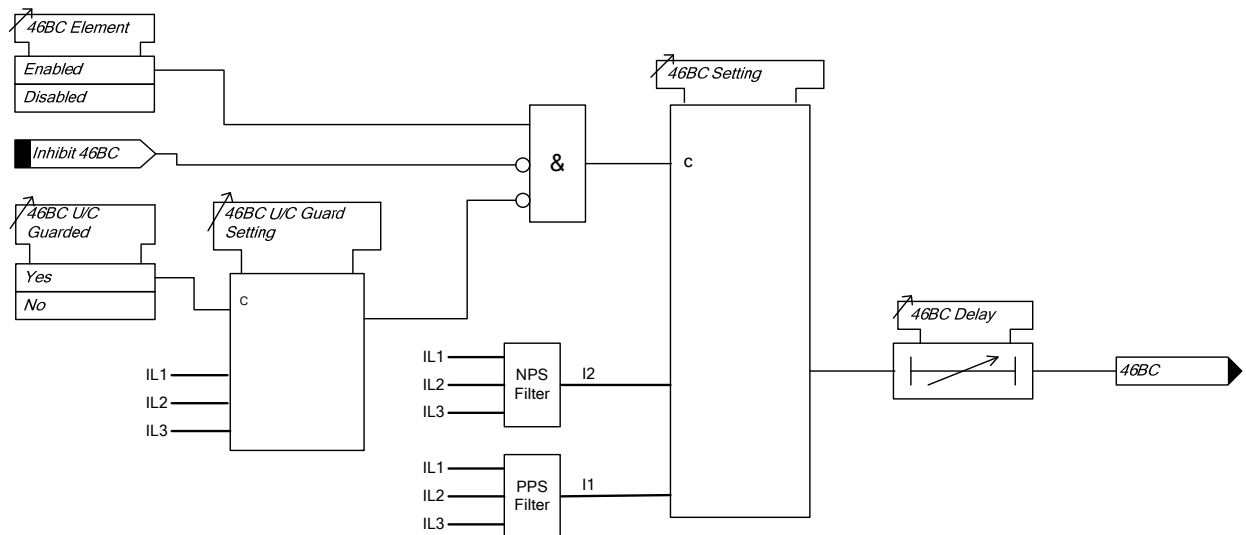

Figure 4-9 Logic Diagram: Broken Conductor Function (46BC)

5.5 Trip/ Close Circuit Supervision (74TCS & 74CCS)

The relay provides three trip and three close circuit supervision elements, all elements are identical in operation and independent from each other allowing 3 trip and 3 close circuits to be monitored.

One or more binary inputs can be mapped to **74TCS-n**. The inputs are connected into the trip circuit such that at least one input is energised when the trip circuit wiring is intact. If all mapped inputs become de-energised, due to a break in the trip circuit wiring or loss of supply an output is given.

The **74TCS-n Delay** setting prevents failure being incorrectly indicated during circuit breaker operation. This delay should be greater than the operating time of the circuit breaker.

The use of one or two binary inputs mapped to the same Trip Circuit Supervision element (e.g. 74TCS-n) allows the user to realise several alternative monitoring schemes.

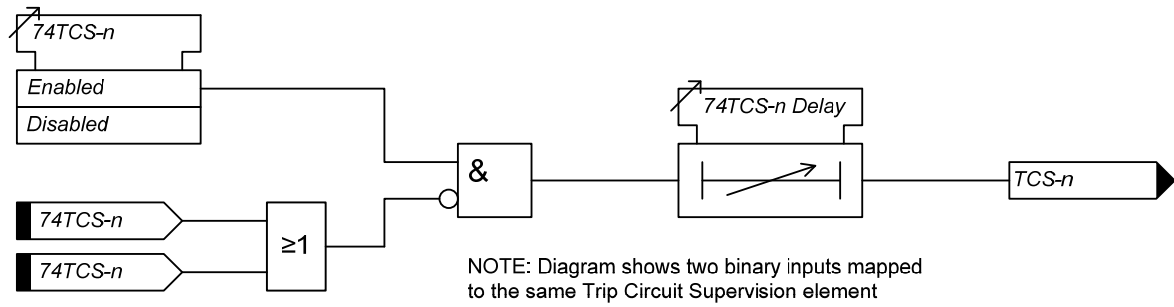

Figure 4-10 Logic Diagram: Trip Circuit Supervision Feature (74TCS)

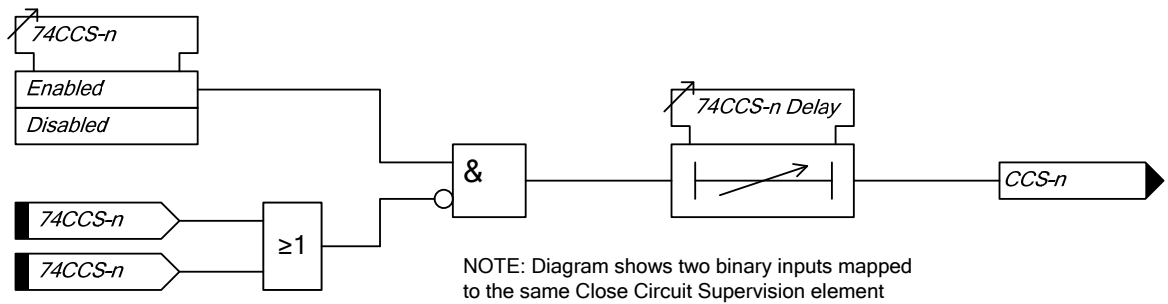

Figure 4-11 Logic Diagram: Close Circuit Supervision Feature (74CCS)

5.6 2nd Harmonic Block/Inrush Restraint (81HBL2) phase elements only

Inrush restraint detector elements are provided, these monitor the line currents.

The inrush restraint detector can be used to block the operation of selected elements during transformer magnetising inrush conditions.

The **81HBL2 Bias** setting allows the user to select between **Phase**, **Sum** and **Cross** methods of measurement:

- Phase** Each phase is inhibited separately.
- Sum** With this method the square root of the sum of the squares of the second harmonic in each phase is compared to each operate current individually.
- Cross** All phases are inhibited when any phase detects an inrush condition.

An output is given where the measured value of the second harmonic component is above the **81HBL2** setting.

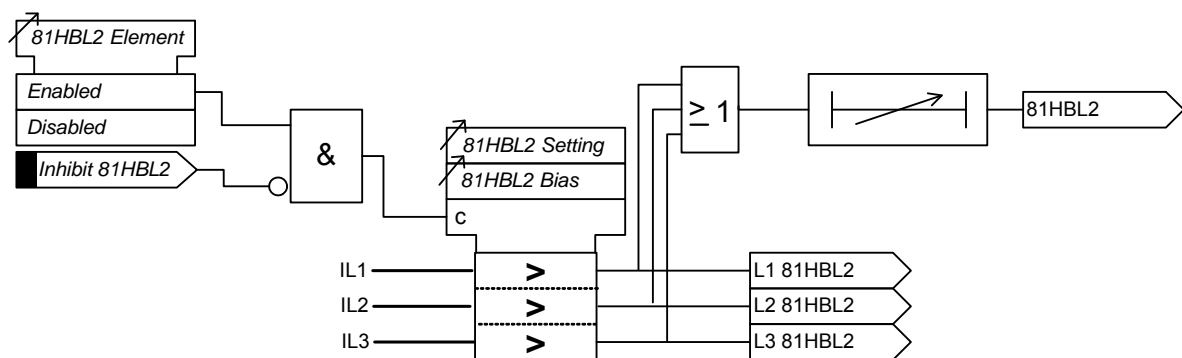

Figure 4-12 Functional Diagram for Harmonic Block Feature (81HBL2)

Section 6: Other Features

6.1 Data Communications

Two communication ports, COM1 and COM2 are provided. RS485 connections are available on the terminal blocks at the rear of the relay (COM1). A USB port, (COM 2), is provided at the front of the relay for local access using a PC.

The rear com1 port can be selected to operate as a local or a remote port operation.

Communication is compatible with Modbus-RTU, IEC60870-5-103 FT 1.2 and DNP 3.0 transmission and application standards.

For communication with the relay via a PC (personal computer) a user-friendly software package, Reydisp, is available to allow transfer of relay settings, waveform records, event records, fault data records, Instruments/meters and control functions. Reydisp is compatible with IEC60870-5-103.

Data communications operation is described in detail in Section 4 of this manual.

6.2 Maintenance

6.2.1 Output Matrix Test

The feature is only visible from the Relay fascia and allows the user to operate the relays functions. The test of the function will automatically operate any Binary Inputs or LED's already assigned to that function.

Any protection function which is enabled in the setting menu will appear in the Output Matrix Test.

6.2.2 CB Counters

The following CB maintenance counters are provided:

CB Total Trip Count:	Increments on each trip command issued.
CB Delta Trip Count:	Additional counter which can be reset independently of the Total Trip Counter. This can be used, for example, for recording trip operations between visits to a substation.
CB Count to AR Block: (Only in Auto-reclose models)	Displays the number of CB trips experienced by the CB before the AR is blocked. When the target is reached the relay will only do 1 Delayed Trip to Lockout. An output is available to reset this value.
CB Frequent Ops Count	Logs the number of trip operations in a rolling window period of one hour. An output is available to reset this counter.

Binary outputs can be mapped to each of the above counters, these outputs are energised when the user defined **Count Target** or **Alarm Limit** is reached.

6.2.3 I_{2t} CB Wear

An I_{2t} counter is also included, this can provide an estimation of contact wear and maintenance requirements. The algorithm works on a per phase basis, measuring the arcing current during faults. The I_{2t} value at the time of trip is added to the previously stored value and an alarm is given when any one of the three phase running counts exceeds the set **Alarm limit**. The t value is the time between CB contacts separation when an arc is formed, **Separation Time**, and the CB **Clearance time**.

The I_{2t} value can also triggered and reset from a binary input or command.

6.3 Data Storage

6.3.1 General

The relay stores three types of data: relay event records, analogue/digital waveform records and fault records. Data records are backed up in non-volatile memory and are permanently stored even in the event of loss of

auxiliary supply voltage. The data storage menu contains the settings for the Demand, Waveform and Fault storage features.

6.3.2 Demand

Maximum, minimum and mean values of line currents, voltages and power (where applicable) are available as instruments which can be read in the relay INSTRUMENTS MENU or via Reydisp.

The **Gn Demand Window** setting defines the maximum period of time over which the demand values are valid. A new set of demand values is established after expiry of the set time.

The **Gn Demand Window Type** can be set to **FIXED** or **PEAK** or **ROLLING**.

When set to **FIXED** the maximum, minimum and mean values demand statistics are calculated over fixed Window duration. At the end of each window the internal statistics are reset and a new window is started.

When set to **PEAK** the maximum and minimum values since the feature was reset are recorded.

When set to **ROLLING** the maximum, minimum and mean values demand statistics are calculated over a moving Window duration. The internal statistics are updated when the window advances every **Updated Period**.

The statistics can be reset from a binary input or communication command, after a reset the update period and window are immediately restarted.

6.3.3 Event Records

The event recorder feature allows the time tagging of any change of state (Event) in the relay. As an event occurs, the actual event condition is logged as a record along with a time and date stamp to a resolution of 1 millisecond. There is capacity for a maximum of 1000 event records that can be stored in the relay and when the event buffer is full any new record will over-write the oldest. Stored events can be erased using the DATA STORAGE>**Clear Events** setting or from Reydisp.

The following events are logged:

- Change of state of Binary outputs.
- Change of state of Binary inputs.
- Change of Settings and Settings Group.
- Change of state of any of the control functions of the relay.
- Protection element operation.

All events can be uploaded over the data communications channel(s) and can be displayed in the 'Reydisp' package in chronological order, allowing the sequence of events to be viewed. Events can be selected to be made available spontaneously to an IEC 60870-5-103, Modbus RTU or DNP 3.0 compliant control system. The function number and event number can also be changed. The events are selected and edited using the Reydisp software tool.

For a complete listing of events available in each model, refer to Technical Manual Section 4 'Data Communication'.

6.3.4 Waveform Records.

Relay waveform storage can be triggered either by user selected relay operations, from the relay fascia, from a suitably programmed binary input or via the data comms channel(s). The stored analogue and digital waveforms illustrate the system and relay conditions at the time of trigger. An output is provided to indicate when a new record has been stored.

A waveform can also be stored from the fascia using the DATA STORAGE/Waveform Storage>**Trigger Waveform** setting

In total the relay provides up to 10 seconds of waveform storage, this is user selectable to 1 x 10second, 2 x 5 second, 5 x 2 second or 10 x 1 second records. When the waveform recorder buffer is full any new waveform record will over-write the oldest. The most recent record is Waveform 1.

As well as defining the stored waveform record duration the user can select the percentage of the waveform storage prior to triggering.

Waveforms are sampled at a rate of 1600Hz.

Stored waveforms can be erased using the DATA STORAGE/Waveform Storage>**Clear Waveforms** setting or from Reydisp.

6.3.5 Fault Records

Up to ten fault records can be stored and displayed on the Fascia LCD. Fault records can be triggered by user selected relay operations or via a suitably programmed binary input. An output is provided to indicate when a new record has been stored.

Fault records provide a summary of the relay status at the time of trip, i.e. the element that issued the trip, any elements that were picked up, the fault type, LED indications, date and time. The **Max Fault Rec. Time** setting sets the time period from fault trigger during which the operation of any LEDs is recorded.

The relay can be set to automatically display the fault record on the LCD when a fault occurs by enabling the SYSTEM CONFIG> **Trip Alert** setting. When the trip alert is enabled the fault record will be displayed until the fault is removed.

When examined together the event records and the fault records will detail the full sequence of events leading to a trip.

Fault records are stored in a rolling buffer, with the oldest faults overwritten. The fault storage can be cleared with the DATA STORAGE/Fault Storage>**Clear Faults** setting or from Reydisp.

6.3.6 Energy Storage - 7SR12

The measured Power is continuously integrated (over a one-second window) to produce 4 Energy quantities:

- Active Export Energy (W)
- Active Import Energy (W)
- Reactive Export Energy (VAr)
- Reactive Import Energy (VAr)

The Direction of Energy transfer is set by: SYSTEM CONFIG> **Export Power/Lag VAr**. With both **Export Power** (W) and **Lag VAr** (VAr) set to be **+ve**, the Direction of Energy transfer will follow the IEC convention, as shown in the figure.

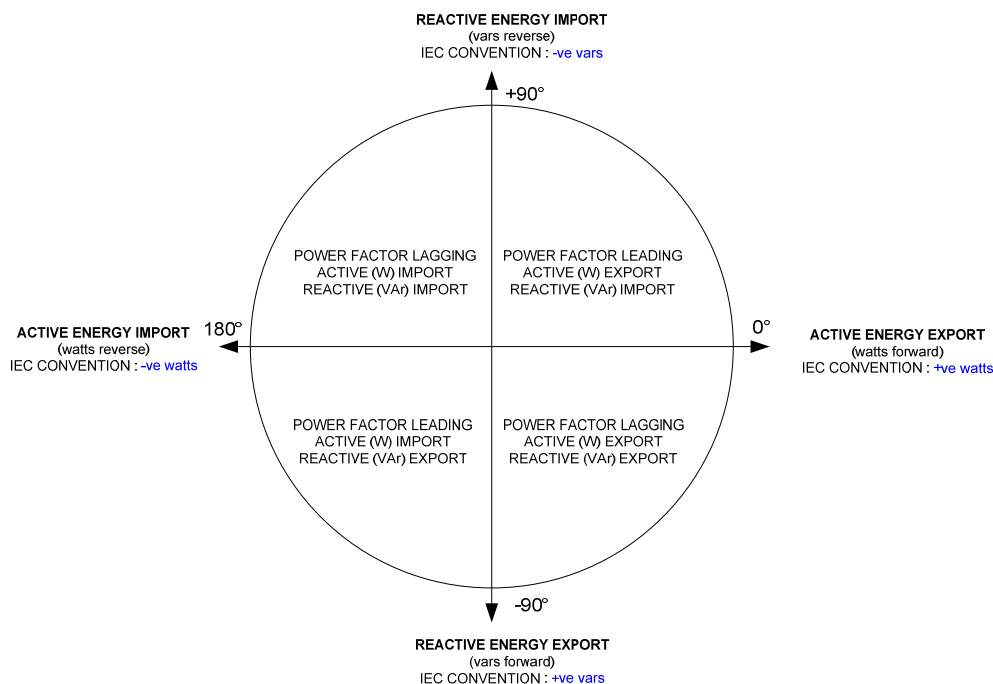

Figure 4-13 Energy Direction Convention

Setting either the **Export Power** (W) or **Lag VAr** (VAr) to be **-ve**, will reverse the Direction of the Energy transfer for these quantities. So forward VAr will then be reported as Imported Reactive Energy, and forward Watts will be reported as Exported Active Energy.

When the accumulated Energy quantities reach a set increment, the Relay issues a pulse to the binary outputs: OUTPUT CONFIG/OUTPUT MATRIX> **Active Exp Pulse**, **Active Imp Pulse**, **Reactive Exp Pulse** and **Reactive Imp Pulse**.

The Energy increments are set by the settings: DATA STORAGE/ENERGY STORAGE> **Active Exp Energy Unit**, **Active Imp Energy Unit**, **Reactive Exp Energy Unit** and **Reactive Imp Energy Unit**. These setting also define the resolution of the stored energy values reported by instruments and communications protocols. The value is stored in the range 0-999999 which continues from zero automatically when 999999 is reached.

6.4 Metering

The metering feature provides real-time data available from the relay fascia in the 'Instruments Mode' or via the data communications interface.

The Primary values are calculated using the CT and VT ratios set in the **CT/VT Config** menu.

The text displayed in the relays 'Instruments Mode' associated with each value can be changed from the default text using the Reydisp software tool.

The user can add the meters that are most commonly viewed to a 'Favourites' window by pressing 'ENTER' key when viewing a meter. The relay will scroll through these meters at an interval set in the **System Config/Favourite Meters Timer** menu.

The energy storage meters can be reset from a binary input and have a user selectable setting for their measurement in the **Data Storage/Energy storage menu**.

For a detailed description refer to Technical Manual Chapter 2 – Settings and Instruments.

6.5 Operating Mode

The relay has three operating modes, Local, Remote and Out of Service. The following table identifies the functions operation in each mode.

The modes can be selected by the following methods:

SYSTEM CONFIG>*OPERATING MODE* setting, a Binary Input or Command

Table 4-1 Operating Mode

OPERATION	REMOTE MODE	LOCAL MODE	SERVICE MODE
Control			
Rear Ports	Enabled	Disabled	Disabled
Fascia (Control Mode)	Disabled	Enabled	Disabled
USB	Disabled	Enabled	Disabled
Binary Inputs	Setting Option	Setting Option	Enabled
Binary Outputs	Enabled	Enabled	Disabled
Reporting			
Spontaneous			
IEC	Enabled	Enabled	Disabled
DNP	Enabled	Enabled	Disabled
General Interrogation			
IEC	Enabled	Enabled	Disabled
DNP	Enabled	Enabled	Disabled
MODBUS	Enabled	Enabled	Disabled
Changing of Settings			
Rear Ports	Enabled	Disabled	Enabled
Fascia	Enabled	Enabled	Enabled
USB	Disabled	Enabled	Enabled
Historical Information			
Waveform Records	Enabled	Enabled	Enabled
Event Records	Enabled	Enabled	Enabled
Fault Information	Enabled	Enabled	Enabled
Setting Information	Enabled	Enabled	Enabled

6.6 Control Mode

This mode provides convenient access to commonly used relay control and test functions. When any of the items listed in the control menu are selected control is initiated by pressing the ENTER key. The user is prompted to confirm the action, again by pressing the ENTER key, before the command is executed.

Note that a CB must be in a Closed state before an Open command will be accepted. And that a CB must be in an Open state before a Close command will be accepted. If not, the Relay reports that the requested command is 'Interlocked'.

Note also that switching a protection function IN / OUT via the Control Menu will not change that function's ENABLED / DISABLED setting. The Control Menu selection will over-ride the setting, however.

Control Mode commands are password protected using the Control Password function – see Section 6.9.

6.7 Real Time Clock

Time and date can be set either via the relay fascia using appropriate commands in the System Config menu or via the data comms channel(s). Time and date are maintained while the relay is de-energised by a back up storage capacitor. The length of time for which this data will be maintained will depend on such things as temperature, length of time in service, etc. However the data will be maintained for a minimum of 1.8 days.

In order to maintain synchronism within a substation, the relay can be synchronised to the nearest second or minute using the communications interface, or a binary input.

The default date is set at 01/01/2000 deliberately to indicate the date has not yet been set. When editing the **Time**, only the hours and minutes can be edited. When the user presses **ENTER** after editing the seconds are zeroed and the clock begins running.

6.7.1 Time Synchronisation – Data Communication Interface

Where the data comms channel(s) is connected the relay can be directly time synchronised using the global time synchronisation. This can be from a dedicated substation automation system or from 'Reydisp Evolution' communications support software.

6.7.2 Time Synchronisation – Binary Input

A binary input can be mapped **Clock Sync from BI**. The seconds or minutes will be rounded up or down to the nearest value when the BI is energised. This input is leading edge triggered.

6.8 Settings Groups

The relay provides four groups of settings – Group number (Gn) 1 to 4. At any one time only one group of settings can be 'active' – SYSTEM CONFIG>**Active Group** setting. An output is provided to indicate which setting group is active.

It is possible to edit one group while the relay operates in accordance with settings from another 'active' group using the **View/Edit Group** setting.

Some settings are independent of the active group setting i.e. they apply to all settings groups. This is indicated on the top line of the relay LCD – where only the **Active Group No.** is identified. Where settings are group dependent this is indicated on the top line of the LCD by both the **Active Group No.** and the **View Group No.** being displayed.

A change of settings group can be achieved either locally at the relay fascia, remotely over the data comms channel(s) or via a binary input. When using a binary input an alternative settings group is selected only whilst the input is energised (**Select Grp Mode: Level triggered**) or latches into the selected group after energisation of the input (**Select Grp Mode: Edge triggered**).

Settings are stored in non-volatile memory.

6.9 Password Feature

The relay incorporates two levels of password protection – one for settings, the other for control functions.

The programmable password feature enables the user to enter a 4 character alpha numeric code to secure access to the relay functions. The relay is supplied with the passwords set to **NONE**, i.e. the password feature is disabled. The password must be entered twice as a security measure against accidental changes. Once a password has been entered then it will be required thereafter to change settings or initiate control commands. Passwords can be de-activated by using the password to gain access and by entering the password **NONE**. Again this must be entered twice to de-activate the security system.

As soon as the user attempts to change a setting or initiate control the password is requested before any changes are allowed. Once the password has been validated, the user is 'logged on' and any further changes can be made without re-entering the password. If no more changes are made within 1 hour then the user will automatically be 'logged off', re-enabling the password feature.

The Settings Password prevents unauthorised changes to settings from the front fascia or over the data comms channel(s). The Control Password prevents unauthorised operation of controls in the relay Control Menu from the front fascia.

The password validation screen also displays a numerical code. If the password is lost or forgotten, this code should be communicated to Siemens Protection Devices Ltd. and the password can be retrieved.